

THE OFFICIAL JOURNAL OF THE SOCIETY FOR INFORMATION DISPLAY

INFORMATION DISPLAY

JULY 1985

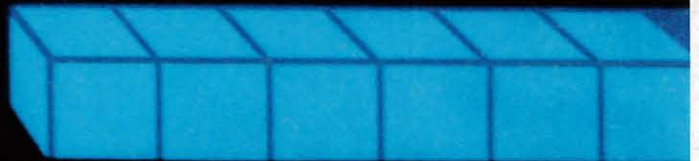
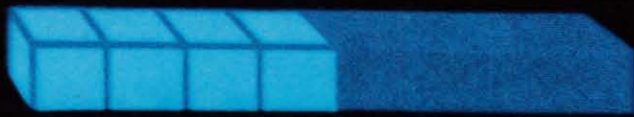

LITERS



GALLONS

**AUTOMOTIVE
INSTRUMENTATION
DISPLAYS:
TECHNOLOGIES
AND TRENDS**

036842B

CA 95009

GUS CARROLL
CARROLL CONSULTING CO
PO BOX 127
CAMPBELL

NON-PROFIT ORG
U.S. Postage
PAID
Permit No. 324
Framingham, MA

Designing or buying 200MHz video monitors?

We have a tool made just for you.

Imagine yourself trying to design or evaluate a new color graphics monitor when the logic to drive it is still eight weeks from working!

With OPIX you can not only drive the monitor—you can create a full color graphics image similar to one your end product might produce—today!

YOU have control of the syncs, the scan rate—the video image itself. Construct a test image that will help *YOU* best during the design or evaluation phase of your monitor.

Here's what OPIX gives you:

- 1.6-200 MHz pixel rate.
- Selection of 256 colors from over 16 million.
- Text and graphics in the same image.
- Non-volatile image storage.
- RS-232 & IEEE-488 interfaces.

With all this flexibility, you might think that operating OPIX has to be a nightmare. Actually, it's quite simple. You make changes by simply pointing to values with a button and "tweaking" them with a knob. OPIX "understands" the way a video display works—so it responds as you'd expect.

If you have a project that needs a signal generator, we know you'll like OPIX. Call us. (312) 668-3301

 **QUANTUM DATA™**

455 E. Kehoe
Carol Stream, IL 60188
(312) 668-3301
TELEX 206 725



Magnetic Shield Manufacturing



REPRODUCIBLE QUALITY — ON COMMAND!

COMPETITIVE EDGE

Eagle Magnetic's willingness to invest in expandable state-of-the-art automated manufacturing and control equipment reflects our desire to continue our competitive edge, serving our customers, well into the future.

CAD/CAE to CAM

Productivity begins with our sophisticated Computer process control center. Here advanced high-level programming, link design/engineering specifications to optimum machine operation. Precise monitoring compounds value added by increased machine uptime, reduced waste, and repeatable accuracy in reproducing your exact design specifications —now— or a year from now.

MORE THAN AUTOMATION

CNC/DNC and NC machines provide the precision and long term repeatability required to produce the consistent, high quality—value added products you deserve.

In addition to automated equipment, our up-rated semi-automatic and operator directed machines provide important alternatives for selecting the most cost-effective process methods.

CRAFTSMENSHIP

Talented craftsmen combine knowledge and experience, with proven

CAM and up-to-the-minute fabrication techniques.

Pride of workmanship and a creative environment, result in quick, practical solutions to production problems.

You will benefit from our improved process consistency and greater productivity.

BENCHMARK QUALITY

Eagle Magnetic Benchmark Quality is our manufacturing standard. We believe value added quality is a **design-in** feature not an inspect-in incident. Skillful management of committed individuals operating state-of-the-art CAD/CAE/CAM equipment increase **design-in** value added quality with each process.

Quality begins when design specifications are CAD/CAE enhanced and continue through master programming, down-loading, and station process control.

Careful handling and shipping insures that you receive a high quality value added product.

RESPONSIVE

If you expect high quality, value added shield products, manufactured to your exacting specifications, by the latest automated technology, then you should contact Eagle Magnetic Co.—the technology leader in the material selection and production of shields to solve EMI problems.

Design



Prototype



Production

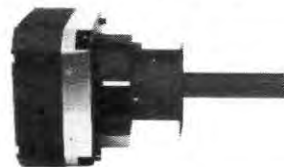

Eagle Magnetic Co. Inc.

Magnetic Shields (CRT—XTM—PM) Sheet & Foil

P.O. Box 24283, Indianapolis, IN 46224

317-297-1030

Gun Control.

At Southwest Vacuum Devices we solve gun control problems. Prototypes. Research. Design. Manufacturing.

We sole source guns and gun components for top U.S. OEMs.

Short runs cost you money, time, productivity. That's an area in which we excel.

Use us as an extension of your own engineering and production facilities.

As a domestic supplier we are only overnight, not oceans apart.

For solutions to your gun control problems, call or write us today.



Complete Guns, Stems, Cathodes,
Other Components



SOUTHWEST VACUUM DEVICES, INC.

P.O. Box 50524/Tucson, Arizona 85703
(602) 887-7900 Telex 165-522

Events

NATIONAL

AUGUST 18-23: SPIE's 29th Annual Technical Symposium on Optics and Electro-Optics, San Diego, CA. Contact: SPIE, PO Box 10, Bellingham, WA 98227-0010 (206/676-3290)

AUGUST 26-29: 1985 AGM SIGMETRICS Conference on Measurement and Modeling of Computer Systems, Austin, TX. Contact: Herbert D. Schwetman, MCC, 9430 Research Blvd., Austin, TX 78759 (512/343-0860)

AUGUST 27-29: INTECH - Integrated Information Technology, Moscone Center, San Francisco, CA. Contact: Sam Smith, National Trade Productions (703/683-8500)

SEPTEMBER 3-6: Office Automation Third Annual Conference and Workshop, Radisson South Hotel, Bloomington, MN. Contact: Jackie Potts, Office Automation Society International, 2108 C Gallows Rd., Vienna, VA 22180 (703/790-0490)

SEPTEMBER 10-12: Third Annual AVIOS Conference, San Francisco, CA. Contact: American Voice I/O Society (AVIOS), PO Box 60940, Palo Alto, CA 94306 (408/742-2539)

SEPTEMBER 10-12: Seventh Annual Electrical Overstress/Electrostatic Discharge Symposium, Minneapolis, MN. Sponsors: ITT Research Institute and the EOS/ES D Assn. Contact: Les Avery, RCA David Sarnoff Research Center, Route 1, Princeton, NJ 08540 (609/734-3009)

SEPTEMBER 15-20: Cambridge Symposium on Optical and Electro-Optical Engineering, Cambridge, MA. Contact: SPIE, PO Box 10, Bellingham, WA 98227-0010 (206/676-3290)

SEPTEMBER 16-18: International Industrial Controls Conference and Expo (IIC '85), Long Beach Convention Center, Long Beach, CA. Contact: Ed Troogstad, Tower Conference Mgt. Co. (312/668-8100)

SEPTEMBER 18-20: FOC/LAN '85 (Local Networks and Fiber Optics), Brooks Hall, San Francisco, CA. Contact: Michael O'Bryant, Information Gatekeepers Inc. (617/232-3111)

SEPTEMBER 19: Fiber Optics: Technology and Applications (Videoconference Seminar). Contact: IEEE Continuing Education Dept., IEEE Service Center, 445 Hoes Lane, Piscataway, NJ 08854 (201/981-0060, ext. 329)

SEPTEMBER 23-25: SPACE TECH 85 Conference and Exposition, Anaheim, CA. Sponsors: Aerospace

and Electronic Systems Soc. of IEEE, American Soc. of Mechanical Engineers, American Soc. for Metals, American Soc. of Quality Control, Computer and Automated Systems Assn. of SME, IEEE Computer Soc., Industrial Electronics Soc. of IEEE, Robotics International of SME. Contact: Soc. of Manufacturing Engineers, One SME Dr., PO Box 930, Dearborn, MI 48121 (313/271-1500)

SEPTEMBER 29-October 3: The Human Factors Society 29th Annual Meeting—"Progress for People." Baltimore, MD. Contact: Ann Amrhein, Waverly Press Inc., 428 E Preston St., Baltimore, MD 21202.

OCTOBER 7-8: 13th IFAC/IFIP Workshop on Real-Time Programming, Purdue University, West Lafayette, IN. Contact: American Federation of Information Processing Societies Inc., 1899 Preston White Drive, Reston, VA 22091 (703/620-8900)

OCTOBER 8-10: Electronic Imaging, Sheraton-Boston Hotel, Boston, MA. Sponsor: Morgan-Grampion Expo. Group. Contact: Ed Martin (617/232-5470)

OCTOBER 8-10: International Robot Conference & Exhibition (InteRobot), San Mateo Exposition Center, San Mateo, CA. Contact: Tower Conference Management Co., Jim May (312/668-8100)

INTERNATIONAL

AUGUST 25-28: Second International Symposium on the Stability and Preservation of Photographic Images, Delta Ottawa Hotel, Ottawa, Canada. Contact: Klaus B. Hendricks, Gen. Chairman, Society of Photographic Scientists and Engineers, 7003 Kilworth Lane, Springfield, VA 22151 (703/642-9090)

SEPTEMBER 2-5: The Third Conference on Human Choice and Computers, Stockholm, Sweden. Co-sponsors: Swedish Society for Information Processing, Central Organization of Salaried Employees in Sweden, and the Swedish Employers' Confederation. Contact: Secretariat, HCC 3, % RESO Congress Service, S-105 24 Stockholm, Sweden.

SEPTEMBER 2-6: Ninth Congress of the International Ergonomics Assn., Bournemouth, England. Contact: Congress Secretariat, Ninth Congress of the International Ergonomics Assn., Meon House, Petersfield, Hampshire, GU32 3JN, England.

(Continued on p.6...)

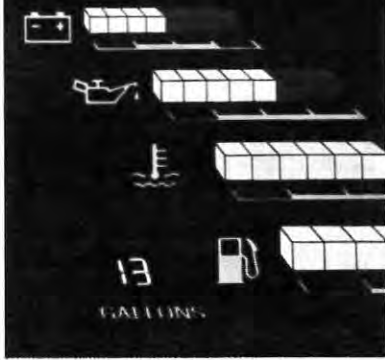

Cover: Electronic instrument cluster consists of a four-color liquid crystal display that measures 11.4 in. by 4 in. and includes speedometer, odometer, trip odometer and tachometer; and an eight-segment bar-graph (shown) fuel level, temperature, voltmeter, and oil pressure gauges (page 21).
 — Ford Motor Co., Dearborn, MI.

FEATURES

Logic, inspiration generate first thin cathode tube 12

Inventions often are the direct result of an inspirational flash. But development of the Kaiser-Aiken Thin Cathode Ray Tube was more an outgrowth of a deliberate attempt to reduce the size of existing tubes. —W. Ross Aiken

Automotive displays: Technologies and trends 16

Automotive electronic instrumentation is a relatively new display field that is undergoing rapid development in response to new applications. —Robert A. Grimm, and others, AC Spark Plug Div., GMC

Microprocessor controls vacuum fluorescent display 17

An electronic instrument panel, consisting of a cluster of Vacuum Fluorescent Displays (VFDs), provides required and supplemental driver information for the 1985 Chrysler H-body series of vehicles. —Gary A. Long, Chrysler Corp. and Hugo Korn, Motorola Inc.

Cold cathode tubes backlight two-color LCD instrument panel 20

Liquid crystal displays provide a number of features that make them particularly suited for electronic automotive instrument panels. —Shigeru Okabayashi, and others, Nissan Motor Co.

Navigational feature at heart of CRT information center 21

An interactive CRT vehicle information center, designed for the Continental CONCEPT 100 vehicle, displays a variety of automatic features on a single device—simply by touching the CRT screen. —Mark W. Jarvis and Richard C. Berry, Ford Motor Co.

afips
 American Federation
 of Information
 Processing Societies

DEPARTMENTS

Events	2
Feedback	4
Short Courses	6
Technology Update	7
Products	26
President's Message	32
Sustaining Members	33
Chapter Notes	34
Advertiser's Index	36

INFORMATION DISPLAY (The Official Journal of the Society for Information Display) is edited for corporate research and development management; and engineers, designers, scientists, and ergonomists responsible for design and development of input and output display systems used in various applications such as: computers and peripherals, instruments and controls, communications, transportation, navigation and guidance, commercial signage, and consumer electronics.

Dynamic display sought

I am interested in LCD graphic displays that can perform dynamic display of a running signal from left to right (like scope). The desired dimensions would be 256 x 32 (but these are not critical).

I would like to indicate that in this mode columns, rather than rows, have to be represented by successive addresses in memory. Another feature, which can facilitate the updating of the dynamic display, is that the RAM address correspond to the dots in the matrix in a flexible manner so that there will not be a necessity to update all the RAM addresses each time the image is moving.

I would be much obliged if you could send me information about such displays.

*David Adler, Head
Biomedical Engineering Unit
Hadassah University Hospital
il-91 120 Jerusalem, Israel
Telex 26278 hadas i1*

Large format LCD screen

We are presently interested in the production of a device requiring a large format LCD screen—ideally something in the 10" x 10" range. It is quite apparent that such screens exist, as they are presently being used in such devices as the Data General One, and the Static Systems Corp. display copier advertised in your May '85 issue.

This letter is the result, however, of my increasing frustration in trying to track down suppliers of such screens. After writing to a number of obvious possibilities, I received some brochures indicating that their largest screens were roughly half the size we require.

I wonder if, perhaps, someone connected with your journal could supply me with information... regarding manufacturers of such large format screens? I should mention that the ideal screen for our purposes would be a full-color one, hence any information on the state-of-the-art in that field (indeed the name of anyone producing such a screen) would also be of great interest...

I quite appreciate that this is above and beyond the call of a journal's normal operations. But, any help would be singularly appreciated.

*Rod Petersen
General Manager
The Tellus Communications Group
#108, 63 Chadwick Place
Halifax, NS B3M 3N6, Canada*

**ID READERS
WE WELCOME YOUR
FEEDBACK, AND
YOUR ORIGINAL
INPUT TOO.**

Westinghouse CRT's have the durability and dependability to explore outer space or inner earth.

Whatever your requirements for display or recording systems, Westinghouse can build a CRT to meet them. For more than 30 years, we've used our design expertise to build durable, dependable CRT's for a wide range of applications including:

- Heads-up display
- Energy exploration

- Air traffic control
- Military monitor displays
- Phototypesetting
- Large screen projection systems
- Microfilm systems

- Medical & X-Ray
- Color recording
- Multi-function heads-down display

For solving your CRT display or recording application problems, look to Westinghouse.

Call or write Westinghouse, Industrial and Government Tube Division, Horseheads, NY 14845. (607) 796-3350.



You can be sure... if it's Westinghouse



EDITORIAL STAFF

Joseph A. MacDonald
Editorial Director

William W. Jacobus, Jr.
Consulting Editor

Lee Harrison
Associate Editor

Lindley R. Higgins, P.E.
Associate Editor

Ted Lucas
Editorial Consultant

Katherine S. Moorehead
Art Editor

EDITORIAL ADVISORY BOARD

Dr. Ifay F. Chang
Chairman
Disp. Tech. Mgr.
Thomas J. Watson
Research Center, IBM

Dr. Frederick J. Kahn
Vice President
Greyhawk Systems Inc.

Koh-Ichi Miyaji
Professor
Shibaura Institute
of Technology

Jan Rajchman
Consultant

Aron Vecht
Director
Phosphor Products Co.

INFORMATION DISPLAY (ISSN 0362-0972) is published monthly by MetaData Inc., 310 East 44 Street, New York, NY 10017. Telephone: 212/687-3836

Subscription: US & Canada - \$36 one year, \$64 two years, \$90 three years; Elsewhere - \$72 one year, \$128 two years, \$180 three years. Single copy: US & Canada - \$3.00; Elsewhere - \$6.00.

Permission is granted by the copyright owner for libraries and others registered with the Copyright Clearance Center (CCC) to photocopy any article herein for the flat fee of \$2.00 per copy of each article. This permission to photocopy does not extend to any special reports or lists published in this magazine. Payment should be sent directly to the Copyright Clearance Center, 21 Congress Street, Salem, MA 01970.

Copying done for other than personal or internal reference use—such as copying for general distribution, for advertising or promotional purposes, for creating new collective works, or for resale—without the written permission of The Society for Information Display is prohibited. Requests for special permission or bulk orders should be addressed to The Society for Information Display, 8055 West Manchester Avenue, Suite 615, Playa Del Rey, CA 90293. Serial-free code: 0362-0972/85 \$2.00 + \$0.00.

Copyright © 1985 by The Society for Information Display.

“The brightest flashes in the world of thought are incomplete until they have been proved to have their counterparts in the world of fact.”

—John Tyndall

This issue of your Journal contains a number of interesting articles describing the technical and operating features of various types of electronic display systems being used in automotive instrumentation panels. And, in another article, an early SID member recounts his entrepreneurial efforts in developing one of the first functional thin cathode-ray tube displays.

Although the display technology described in these articles has previously been published in other professional society proceedings, our intent in re-editing and presenting them in ID is to provide you with relevant material to which you may not have had access. As your president, Dr. Chang, suggests in his message this month, new ideas are often triggered and knowledge is gained by reading about someone else's successes and failures.

And that's what your Journal is all about. It's a forum for exchanging ideas and learning about what other specialists are doing in the field, particularly in some of the more sophisticated areas of automotive, avionic, medical and military systems.

In coming months, we'll explore these and other topics—for instance, in September, Human Factors; in November, Military Displays. We rely on you, our ID readers, to keep us informed of new developments to provide the technical input required for preparing these articles, and to offer suggestions about new areas worth exploring.

Starting next month, we'll begin featuring a regular editorial department on patents recently granted for display devices and components. Again, this is an effort to provide more ID readers greater access to display technology developments than they might normally have.

Then in September, we'll launch a monthly feature that will profile the newest Sustaining Members that have joined SID.

Remember though, this is your Journal. It can only serve you successfully if you contribute to its success editorially.

Joseph A. MacDonald
Editorial Director

SEPTEMBER 3-6: 2nd International Congress on "Logica, Informatica, Diritto," Florence, Italy. Sponsor: Istituto per la Documentazione Giuridica. Contact: ENIC, Via S. Caterina D'Alessandria, 12, 50129 Florence, Italy.

SEPTEMBER 10-12: COMPINT 85 - Computer-Aided Technology, Montreal, Quebec, Canada. Sponsors: IEEE Computer Soc. and IEEE Montreal Section in cooperation with ACM SIGDA (Design and Automation) and ACM SIGART (Artificial Intelligence). Contact: Stephen G. Leahy, PO Box 577, Desjardins Postal Station, Montreal, PQ H5B 1B7, Canada.

SEPTEMBER 10-13: 9th Data Communications Symposium, Whistler Mountain, British Columbia, Canada. Sponsors: ACM SIGCOMM (Data Communications), IEEE Computer Soc., IEEE Communications Soc. Contact: W.P. Lidinsky, Room 6B 309, AT&T Bell Laboratories, Naperville Wheaton Rd., Naperville, IL 60566 (312/979-6246)

SEPTEMBER 11-13: EUROGRAPHICS '85: Nice, France. Sponsor: INRIA, The French Governmental Research Institute. Contact: Institut National de Recherche en Informatique et en Automatique, Domaine de Voluceau - Rocquencourt - BP 105 - 78153 Le Chesnay Cedex France.

SEPTEMBER 20-21: Kitayakyushu International Conference on Automation and Robotics, Kitayakyushu, Japan. Contact: K. Noro, Professor and Head, Human Factors Engineering, School of Medicine, University of Occupational and Environmental Health, 1-1 Iseigaoka Yahata Nishi Ku, Kitayakyushu 807, Japan.

SEPTEMBER 24-26: The Artificial Intelligence and Fifth Generation Computer Technology Conference and Exhibition (AI/Europa), Wiesbaden, West Germany. Sponsor: TCM Expositions Ltd. Contact: Jim Hay, Tower Conference Mgt. Co. 331 W Wesley St., Wheaton, IL 60187 (312/668-8100)

Short Courses

SEPTEMBER 5-6: Artificial Intelligence - an Applications-Oriented Approach; Washington, DC. Provides an understanding of the design, application, and implementation of an "intelligent" system based on artificial intelligence processing techniques that are directly applicable to the solution of practical problems. The course also discusses how to choose from among the many available options in selecting or designing an intelligent system based on artificial intelligence processing techniques. Fee: \$650. Contact: Stod Cortlyou (800/424-9773) or (202) 676-8520).

SEPTEMBER 8-12: 17th Annual Society for Information Management (SIM) Conference—Managing the Explosion—Boston Marriott, Long Wharf, Boston, MA. Contact: 1985 SIM Conference Office, Suite 600, 111 E Wacker Dr., Chicago, IL 60601 (312/644-6610)

SEPTEMBER 9-13: Fundamentals & Applications of Lasers; Chicago, IL. Explains the fundamental operating principles of lasers and their use in various applications. Course Fee: \$800. Contact: Laster Institute of America, Education Director, 5151 Monroe Street, Suite 102W, Toledo, OH 43623.

SEPTEMBER 18-20: Electronic Computer Printing; Washington, D.C. Covers current and emerging technologies for converting electronically stored information into printed hard-copy products. Participants in this course will gain the ability to define the capabilities and limitations of both foreign and domestic ECP products and peripherals, and to develop operating procedures for ECP applications. Fee: \$730. Contact: Chip Blouin (800/424-9773) or (202/676-8527).

**IDRC
SAN DIEGO
OCT 15 - 17**

Special Purpose Technology Corp.

Design — Development — Production

WE OFFER YOU TECHNICAL ABILITY
FOR ANY SPECIAL CRT'S

TYPICAL SPECIAL PURPOSE CRT'S

FIBER OPTIC FACE
BACK PORTED
MONOSCOPES
ULTRA HIGH RESOLUTION
SUBSCREENS
PROJECTION TUBES
CUSTOM GEOMETRIES,
PHOSPHOR SCREENS,
ELECTRON OPTICS

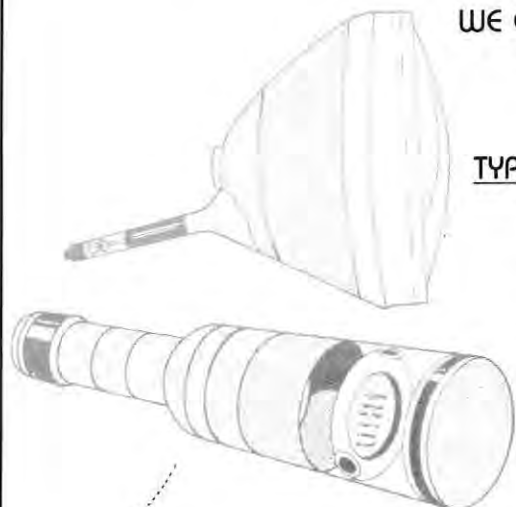

SPECIAL PURPOSE CATHODE RAY TUBES

SPTC, INC.

14746 RAYMER STREET
VAN NUYS, CALIFORNIA 91405

(818) 989-4610 (213) 873-5107

RIT establishes center for imaging science

The Center for Imaging Science, recently established at Rochester (NY) Institute of Technology, will provide research support and do contract work in the areas of remote sensing, digital imaging, optics and robotic vision pertaining to a variety of industries, including graphic arts and photography. It will provide undergraduate and graduate programs in these areas.

Housed in the Institute's College of Graphic Arts and Photography, and under the direction of Dr. William Brouwer, the center will provide interdisciplinary programs in optics, remote sensing, photographic chemistry and image evaluation.

Information display group consolidates graphics divisions

Tektronix Inc.'s Information Display Group, Wilsonville, OR, recently consolidated several of its existing organizations into four major divisions:

- **Graphic Workstations Div.**—formerly the Graphic Systems Products and Engineering Computing Systems Div., provides graphic systems and workstations designed primarily for electrical and mechanical CAD. Artificial Intelligence Machines will remain a separate program entity but will be closely aligned with the Graphic Workstations Div. in terms of product planning and positioning.
- **Terminals Div.**—consolidates the former Graphic Desktop Products Div. and the former Graphic Software Products Div. and is responsible for providing mechanical and electrical engineering design and analysis customers with graphic terminals and software products.
- **Peripherals Div.**—formerly Graphic Peripherals Products, will continue to provide graphic input and output devices, including graphics tablets, automatic digitizing devices and copiers.
- **CAE Div.**—consists of two wholly-owned Tektronix subsidiaries, CAE Systems Inc. (Sunnyvale, CA)

and VR Information Systems Inc. (Austin, TX), as well as Logic Design Systems Div. (Beaverton, OR) and provides CAE products to serve the needs of electronic product design teams—including design capture and design verification tools, as well as physical layout tools.

Optical recognition device parallels eye-brain system

Borrowing techniques from bats and dolphins, researchers at the University of Pennsylvania have developed a radar system that can form images of airplanes, satellites, and other remote objects—day or night, through fog, dust, or other optically opaque material. And, in an offshoot of that project, the researchers are now testing an optical recognition system that works in a manner similar to current theories of how the human eye-brain recognition works.

Dr. Nabil Farhat, professor of electrical engineering at the University of Pennsylvania School of Engineering and Applied Science, has developed a radar tomographic (images in slices) system that can take 3-D microwave pictures. While conventional radar shows only formless blips on a screen, Dr. Farhat's system shows prominent features of an object—sufficient for sight recognition.

A major problem confronting researchers was that production of high-resolution microwave images of distant objects would require a highly impractical aperture lens miles in diameter. And, replacing one very large sensor with a large number of smaller individual sensing devices spread over a large area would be too costly.

So, Farhat sought the solution in the unique capabilities of bats and dolphins, which use sound waves as a radarlike system. Although they have small sensing apertures, both mammals are capable of discerning fine detail by using "chirps" and "clicks" that contain many wavelengths or frequencies, rather than just one.

By using many wavelengths, Farhat was able to get high-resolution images with only one receiver. Each wavelength produces different pieces of informa-

LEVER-LOC® CUSTOM DISPLAY CONNECTORS

The Lever-Loc® series connectors are a fast, reliable solution for interconnecting your flat panel display and driver pcb.

A proven performer, Lever-Loc® connectors are used for applications such as automotive instrument clusters, avionics equipment and medical instrumentation.

The unique "ramp" design allows fast, easy installation with a low insertion force. Pressure contacts provide a reliable interface to the display apron and can be provided on .050", .075", .100" or 2mm spacing.

Each Lever-Loc® connector is custom designed by Teledyne Kinetics to meet our customer's requirements.

The display apron acts as a "lever" to provide a mechanical advantage over the pressure contacts. The display is then slid into place, providing a wiping action.



Call today
for a free catalog

Continental USA

1-800-344-4334

California Only

1-800-992-9988

 **TELEDYNE
KINETICS**

410 S. Cedros Avenue
Solana Beach, CA 92075
(619) 755-1181
EasyLink 62877770



tion; by putting the pieces together, the shape of the entire object can be defined. The microwave imaging process requires a computer to do a Fourier analysis, in the course of which the image is decomposed into gratings and the gratings are analyzed to yield a 2-D or 3-D image.

Farhat's subsequent efforts to develop a means of automatically identifying images, rather than relying on human observation, led to two more developments—a Fourier camera and a device based on a theory of how the human brain works.

The lengthy Fourier transforms required in microwave imaging are too time-consuming for digital computers. But the alternative, optical computing, also has drawbacks because natural light consists of many wavelengths—while optical computers, which use lasers, have only one wavelength.

Farhat's Fourier camera overcomes that problem, since it simply looks at a

scene and does a Fourier transform using natural light. The camera works exactly the way researchers have recently suggested that the eye-brain system does things—analyzing the Fourier components of a scene along radial (spoke-like) directions.

The second device is based on a mathematical model of the neural networks of the human eye-brain system, developed by John Hopfield of Cal Tech. Neural nets consist of at least 10 billion nerve cells that are intricately and massively interconnected. They operate on visual and other sensory data in parallel to perform recognition and association tasks that are so complex and intricate that they would easily tax the computational capabilities of thousands of advanced computers working together.

Farhat and a Cal Tech associate, Demetri Psaltis, found the Hopfield Model ideally suited for optical implementation, which offers certain advantages over electronic microcircuit

implementation. They linked the optical implementation of the model to the Fourier camera to study it as a model of the human eye-brain system.

Such a system has the potential to identify automatically the images produced by Farhat's microwave device. Other possible applications include machine vision for robots, and use in a new generation of computers that would have an associative memory and possess artificial intelligence.

Proposed programming interface endorsed by graphics society

The National Computer Graphics Association Board of Directors recently endorsed the timely completion and adoption of the Programmers Hierarchical Interactive Graphics Standard (PHIGS) currently under development within ANSI and ISO.

Although it supports PHIGS, NCGA is

PRECISE CRT BEAM CONTROL AT A SENSIBLE PRICE

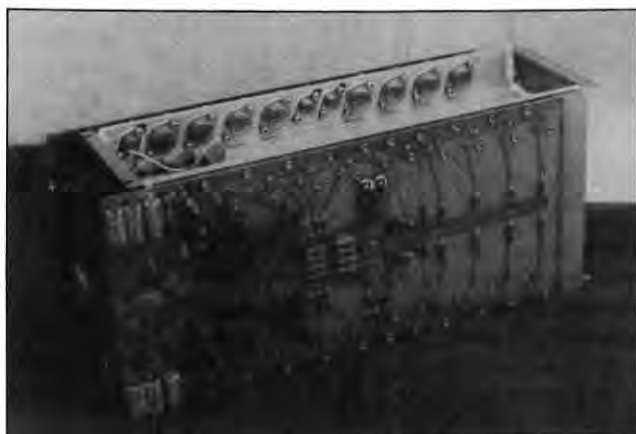

Contact: A. Pletz
Applications Engineer

CITRONIX, Inc.
Post Office Box 288
Orangevale, California 95662
(916) 961-1398

CITRONIX CD-100-6,8 Deflection Amplifier

This X-Y deflection amplifier, available with or without an unregulated power supply, operates from $\pm 20V$ to $\pm 75V$ and can dissipate up to 600 watts per axis.

Check these features:

- Employs low cost unregulated power supplies.
- 2MHZ small signal Bandwidth (with $< 25\mu h$ yoke inductance).
- Proprietary dynamic quiescent control provides Class A operation at all time.
- Safe-Area Operation power monitor and limiter.
- High fin density heat sink design.
- Power saving Voltage-on Demand option.

still firmly committed to the development, acceptance, and widespread use of the GKS computer graphics standards it had endorsed earlier. The association feels that GKS and PHIGS address different needs in the graphics community.

PHIGS is a proposed programming interface for applications requiring rapidly changing pictures, such as real-time simulation. Many of these applications also require 3-D capabilities that are more sophisticated than those dealt with in GKS.

In a resolution prepared by the association's Technical Research and Standards Committee, and approved by its Board of Directors, NCGA has strongly endorsed the stated goal that PHIGS will not technically differ from GKS, except where documented technical justification exists.

For more information, contact: NCGA, 2722 Merrilee Drive, #200, Fairfax, VA (703/698-9600).

Institute formed to monitor research in information science

The Institute for International Information Programs (IIIP) has been established to encourage and foster the participation of US organizations in international information programs and projects and to monitor international research in information science and technology.

Immediate objectives of the Institute, which is headquartered at the College of Library and Information Services (University of Maryland, College Park, MD), are the establishment of a Secretariat, development of a newsletter for exchange of international information, and procurement of funding from private and public sources to support the program.

Long-term objectives include:

- Arranging for US representation in international information organizations.

- Participating in development programs,
- Providing an information link for members of the US community involved in various international meetings,
- Advising the US information community on matters with special emphasis on international matters,
- Informing the US Congress, government agencies, and private corporations on pertinent international issues.

For additional information about IIIP, contact: Dr. Inex Sperr, Executive Director, Migration Information and Abstracts Service, 294 Bunker Hill Rd., Orangeburg, NY 10962 (914/359-8634); or Dr. Paul Wasserman, College of Library and Information Services, 4105 Hornbake Library, University of Maryland, College Park, MD 20742 (301/454-6070).

CONSISTENT COLOR MONITOR DISPLAY

with IRT Visual Color Comparator

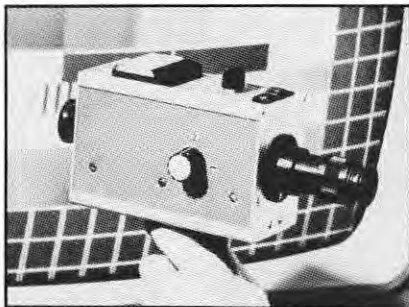

A battery-powered visual comparator for quick and precise color temperature adjustment and gray scale balance of color monitors to recommended world standard of D6500°K.

Over 12 years in service at TV networks and stations.

Bourbon Street Associates
Box 393, So. Salem, NY 105900393

914-763-8893 (In CA. 213-271-9570)

BEST QUALITY/SERVICE YOU CAN COUNT ON CUSTOM/STANDARD LCD



- -40°C TO 95°C STORAGE/OPERATION TEMPERATURE
- LOW POWER/HIGH CONTRAST/WIDE VIEWING
- DICHROIC/PHASE CHANGE TYPES
- PLASTIC PROTOTYPE/GLASS PRODUCTION/DOT MATRIX
- COMMERCIAL/MILITARY STANDARDS
- 2 TO 4 WEEKS DELIVERY

POLYTRONIX, INC.

P. O. BOX 833024, RICHARDSON, TX 75083
(214) 238-7045



Logic, inspiration generate first thin cathode tube

Inventions often are the direct result of an inspirational flash. But development of the Kaiser-Aiken Thin Cathode Ray Tube was more an outgrowth of a deliberate attempt to reduce the size of existing tubes.

In 1951, while working at the University of California at Berkeley for the US Atomic Energy Commission, I set myself on a self-imposed assignment to see if there was some way TV tubes could be made less bulky.

The basic problem was how to scan the CRT face by some method other than the angular deflection of the conventional CRT with its large conical volume. I started my project by outlining the problem:

- The tube depth must be reduced, therefore
- The electron gun could not be in its normal location behind the screen, therefore
- The gun would have to be in another location.

From there, my thinking moved to questions that had to be answered before I could proceed any further. If the gun is not located behind the tube, it must be at a side, on top, or on the bottom. This would mean the electron beam could not be directed at the phosphor screen.

How could a gun function in such a position? The answer was that the beam must be emitted parallel to the screen.

Next, how to deflect the beam into the screen, sweep it across the screen,

and focus it? Electrostatic deflection could bend the beam. But, could the beam be bent 90 deg and still be able to focus on the screen? I assumed it could, and determined that one deflection plate in back of and parallel to the screen would bend the beam into the screen. This meant, however, that the beam would meet the far edge of the screen at a grazing angle and thus not focus well—unless the tube were very small.

What about large tubes? Why not, I thought, put in two plates, three plates, or more. Let each plate take its turn in deflecting, so the beam angle would be kept reasonably uniform.

That solved, I tackled the problem of how to sweep the beam over the screen in two directions. One way would be to deflect the beam at the gun in the conventional manner so that the beam moved in a plane behind the screen. All the plates could be positioned across the direction of the beam; the fan-shaped first deflection would cover the area, and the plate or plates behind the screen would direct the beam into the phosphor. The tube, however, would still be too bulky for a large screen, since the gun must be at sufficient distance to allow the fan sweep to cover the screen area.

How could it be made smaller?

If one multiplate deflection works, so should another. Why not place the gun at a corner, direct the beam parallel to an edge but behind the phosphor, deflect it into a plane behind the phosphor, and then into the phosphor with the various plates?

With the concept thoroughly thought out, I approached my employers. They had no program in which to put such an item, and no funds to spend on it. They gave me a release and I set up my own small lab in a rented basement. I constructed my test model out of a brass box in the shape of a rectangle, with one face open to form a window, and a funnel-like extension on one side. An electron gun was inserted at the end of the extension, a phosphor covered target placed in the window, and several insulated plates set in the rear of the box. The plates were positioned in a plane parallel to the target and at right angles to the beam from the gun.

With my first test, a blurred spot appeared on the phosphor target. The gun controls enabled me to move the spot but not focus it much. After considerable adjustment of deflection plate voltages, the spot moved—as predicted—and went through extremely sharp focus.

Having successfully controlled and focused the beam in my crude test model, my next step was to take development of the thin tube to a prototype stage, which would take a lot of money and time.

To patent, or not

Although I needed financing, I also had to protect my idea. But, should I file for a patent in a hurry? Or wait until I had a detailed description? Waiting could be dangerous, as someone else might get a patent before me. Premature filing was equally dangerous—a sketchy patent would leave openings for others to get

(Continued on p. 14...)

Our new CRTs are quite a handful.

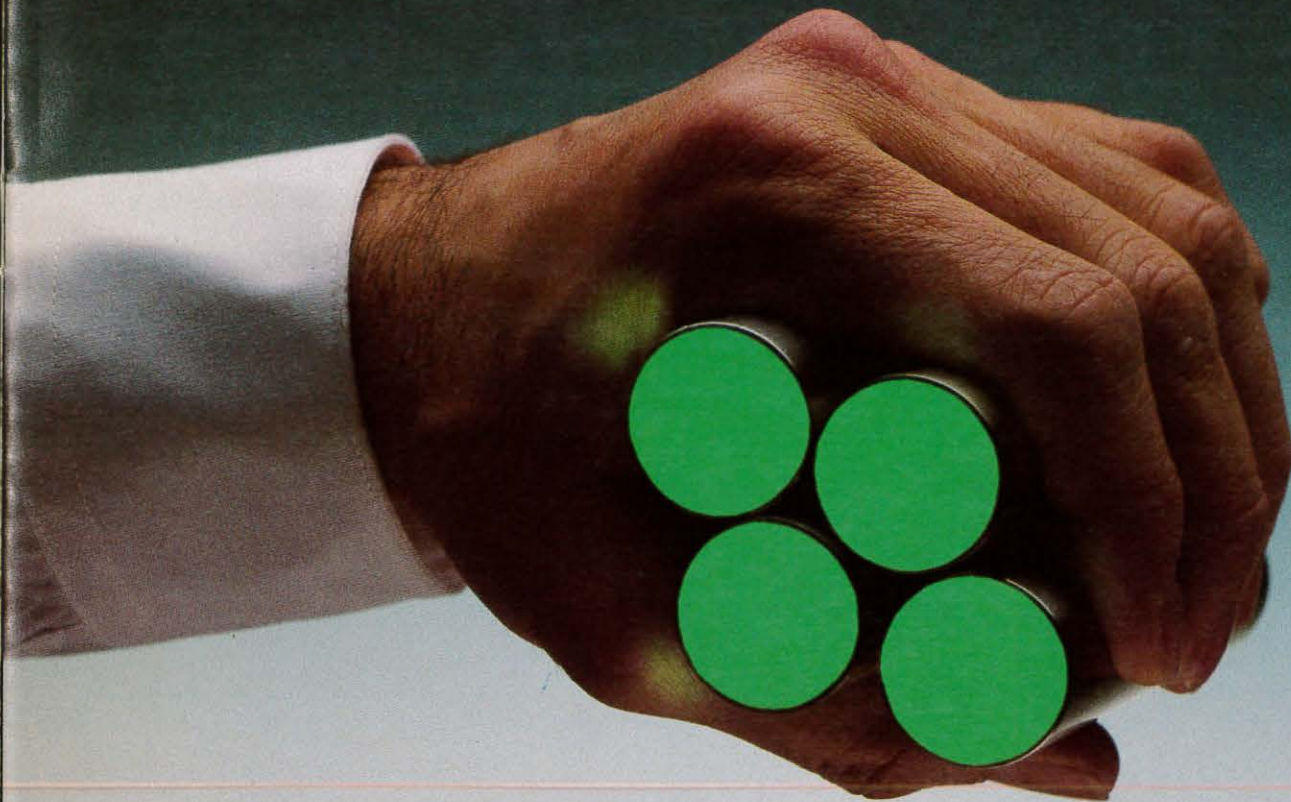

Introducing Litton's 1" tube.

Now let's see. What could you use a miniature CRT for?

How about a helmet-mounted display.

A compact film recorder.

A hybrid typesetter.

Or a compact display inside a crowded tank.

Litton's L-4272 cathode ray tube is the newest sub-miniature on the market.

And one of the best.

It's made by the leader of high resolution, high precision CRT's. Litton's reliable CRT products have been used in everything from advanced reconnaissance systems to sophisticated photo-composition machines.

The L-4272 is ruggedized, so it'll survive inside a tank, an aircraft or any

vehicle using forward-looking infrared systems.

And it's a high performer. Spot size is 0.0008 inch. Brightness is 100 foot-lamberts with standard 525 line TV raster at 30 Hz filling the useful screen.

You can buy it as a stand-alone item or with a small coil and magnetic shield.

To get the small picture, contact Litton Electron Devices Division, 1215 S. 52nd Street, Tempe, AZ 85283. Phone (602) 968-4471. TWX: 910-950-0149.



 **Litton Electron Devices**

(...continued from page 12)

control with even a small item, such as a particular electrode shape or placement, essential to operation but not claimed by me. Also, the omission of an important claim in the first filing could prevent its being covered later; this has sunk many inventors. I decided to wait.

I had originally worked for the Henry J. Kaiser organization, so I approached them with my idea. We discussed and agreed upon an arrangement whereby they could buy the invention, file the patents, and finance the laboratory. I would be put on the project full time as Director of Research.

The first patent was filed in 1953 and work began. Then the bad news hit us. Word leaked from the Patent Office that our application was in trouble—there was an "interference," which meant that someone else had filed a patent on the same idea. (Dr. Dennis Gabor, a professor at Imperial College, London, was the other inventor whose

work was being financed by a British Government Corporation.)

I might not be the first inventor. It could take years to resolve the problem and would cost a lot of money. Kaiser, however, agreed to continue financing my lab, in the hope that my patent would prevail, and to pay the legal costs of the interference. But, almost before we could gear up, Kaiser's auditors announced the funding that was intended to finance the research was no longer available. The project came to a halt.

About that time, George Hoover, a Commander in the Office of Naval Research, Washington, DC, was working on a system of navigation that required a transparent display in aircraft windshields. The display, a "heads up" system, was to superimpose symbols on the real world view, and guide the pilot for navigation, provide aircraft operating parameters, and so forth. We got together, and he liked what he saw.

Hoover had another problem,

though. He also needed a computer to generate the display. And, it had to have sensors, realtime computing power, and more.

Computers in the early 50s, however, used vacuum tubes and had no really practical memory. If the computer could be built, it would take up a large room and require air conditioning. Hoover had just 1 cubic foot of space available to house the system in an aircraft.

Coincidentally, I had recently designed and built a computer occupying very little volume. It used vacuum tubes and magnetic digital counters, and had a handmade rotating drum coated with iron oxide, with closely spaced read/write heads.

Government Contract

There was one condition, however. We could not spend government money for civilian use; we could only work directly on items that the Navy needed. Thus,

(Continued on page...31)



"America's Shielding Source"

- Magnetic Shielding of all types
- Shielding grade alloys
- Total in-house design, testing and manufacturing capabilities.
- Send for our latest product literature.

Magnetic **RADIATION LABORATORIES, INC.**

92-A North Lively Boulevard • Elk Grove Village, Illinois 60007
Phone: 1-312-437-5200 • TWX 910-222-0225

MAKE CRT MEASUREMENTS FAST!!!! BOTH COLOR & MONOCHROME



The versatile **SPOTCHEK** system will permit rapid line width measurements on Monochrome or color CRT's and... provides all those capabilities needed for fast and **accurate** adjustments of CRT system parameters such as: convergence, focus, pincushion, raster line spacing, depth of modulation (mtf), interlace adjustment etc. For further details:

MICROVISION

4855 Atherton Avenue, Suite 201, San Jose, CA 95130
(408) 374-3158 Telex 696191 Att: MICROVISION

Reducing Display Glare to Increase Productivity

Iralin 85

Glare on your computer screen is a disturbing fact of life — whether you're a design engineer, programmer or fifth grader. With Iralin 85, Balzers makes glare a little easier to live with. Iralin 85 anti-reflection coatings cut glare by 94% while providing a sharper, clearer picture with enhanced contrast in numbers, letters and colors. The resulting high quality display will reduce the stress, eye strain and muscle tension associated with extended CRT use and — most important — increase your productivity. So don't let glare get between you and productivity. Make the difference with Balzers Iralin 85 anti-reflection coatings.

Iralin 85 may also be applied to reduce glare on displays utilizing other technologies: LCD, plasma, vacuum fluorescence and electroluminescence.

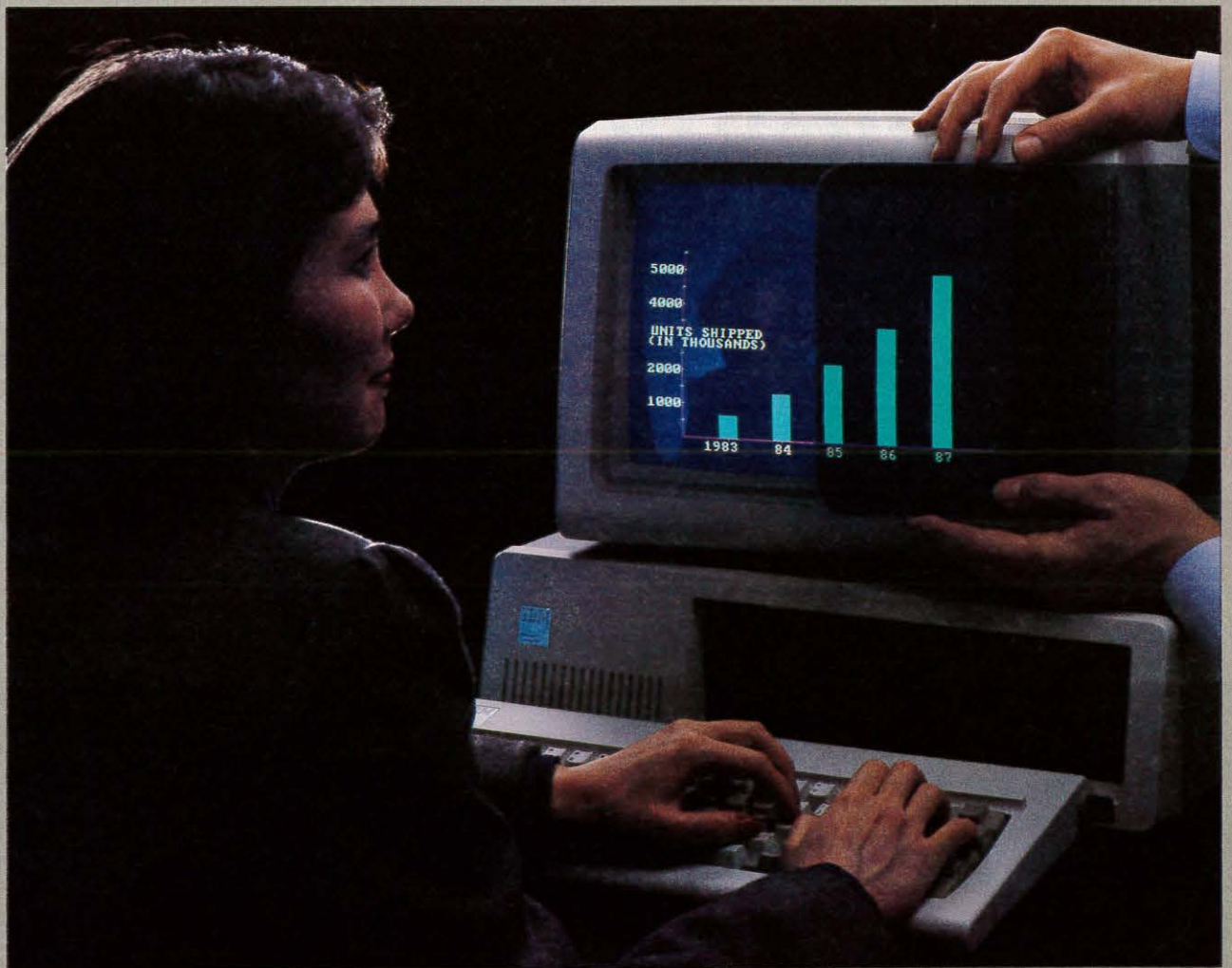

BALZERS

Balzers Optical Group
170 Locke Drive
Marlborough, MA 01752
Tel: (617) 481-9860
Telex: 951 562

Automotive displays: Present technologies and future trends

Automotive electronic instrumentation is a relatively new display field that is undergoing rapid development in response to new applications. In a relatively few years, automotive displays have evolved from simple, single-point light emitting diode (LED) indicators to today's comprehensive electronic display panels that incorporate such technologies as vacuum fluorescent (VF) and liquid crystal (LC) display systems. And, already, a new generation of automotive information centers, using Cathode-Ray Tube (CRT) graphic displays has been successfully developed and proved in a functional automotive environment.

Electronic display functions are found on most of today's luxury automobile instrument panels, and they are rapidly being offered on a broader range of vehicles. Functions include speedometer, tachometer, odometer, engine-coolant temperature and fuel level indicators, trip functions, driver information center, radios and clocks.

Several kinds of display technologies are employed in today's automotive instrumentation panels:

- **Vacuum Fluorescent**—these displays are becoming predominant for radios—at the expense of earlier LEDs. (Some new applications are still being found for LEDs, though, as efforts are made to improve sunlight visibility and to add blue to the list of available colors.)

- **Liquid Crystal**—These displays have rapidly entered automotive appli-

cations in the past two years, as a result of liquid crystal technology having attained a level of sophistication that matches the uncompromising requirements of the automotive environment.

- **Gas Discharge**—this type of display, at least for the present, has disappeared from automotive applications.

- **Cathode-Ray Tubes**—Recent developments and implementation of CRT

displays in concept models for automotive information centers represent the next generation of driver aid. These newer systems permit the grouping of various automotive display units into a single display device. A CRT display can enhance the presentation of current electronic display features and it has the potential to create new, graphic-oriented features.

To provide a historical perspective of the introduction of electronic displays for automotive instrumentation, a MILESTONE CHART (Fig. 1) was devel-

oped that shows the first product offerings in each of four display technologies by Detroit's Big Three automakers.

ELECTRONIC DISPLAY MILESTONE EVENTS

MODEL YEAR	GENERAL MOTORS	FORD	CHRYSLER
1974			• LED GAGE WARNING SYSTEM
1975	• LOW FUEL WARNING (LIGHT EMITTING DIODE)		
1976			
1977	• CLUSTER AND TRIP COMPUTER (GAS DISCHARGE DISPLAY)		• CLOCK (VACUUM FLUORESCENT)
1978	• CLUSTER AND TRIP COMPUTER (VACUUM FLUORESCENT)	• MILES TO EMPTY (GAS DISCHARGE DISPLAY)	
1979		• ELECTRONIC RADIO DISPLAY (VACUUM FLUORESCENT) • CLOCK (VACUUM FLUORESCENT)	• ELECTRONIC RADIO DISPLAY (VACUUM FLUORESCENT) • TRIP COMPUTER (VACUUM FLUORESCENT)
1980	• CLUSTER AND TRIP COMPUTER (VACUUM FLUORESCENT) • FUEL MONITOR (LIGHT EMITTING DIODE)	• CLUSTER (VACUUM FLUORESCENT) • CLUSTER W/MESSAGE CENTER (VACUUM FLUORESCENT)	
1981	• CLOCK (VACUUM FLUORESCENT)		• CLUSTER (VACUUM FLUORESCENT)
1982		• TRIP COMPUTER (VACUUM FLUORESCENT)	
1983	• DIAGNOSTIC/SERVICE DISPLAY (LIQUID CRYSTAL) • CLUSTER, STANDARD EQUIP. (LIQUID CRYSTAL)		• TRIP COMPUTER (VACUUM FLUORESCENT)

TABLE 1

by Robert A. Grimm, and others,
AC Spark Plug Div., GMC

The challenge facing the automotive instrumentation design engineer is to produce an attractive, easy-to-read instrument display panel. It must be reliable, reproduceable, and dependable under exposure to the adverse automotive environment. And it must take into consideration—both from the human factors standpoint and from the marketing viewpoint—the amount of complexity a car buyer wants.

Higher technical standards in automotive developments, particularly the introduction of microprocessors to control a variety of automotive functions, have created a necessity for a vehicle operator to be supplied with more and more information and recommendations. Because of this need, and the need to reduce cost and space the trend in automotive displays today is toward a greater use of graphics.

(This article was developed from "Electronic Displays—Automotive Applications," by Robert A. Grimm, David G. Beyerlain, John C. Engelman, and John A. Carol, Jr., AC Spark Plug Div., GMC; Copyright 1984, Society of Automotive Engineers, SP 565; Electronic Displays and Information Systems, Paper No. 830906.)

Micro controls vacuum fluorescent instrument display

A unique electronic instrument panel, consisting of a cluster of Vacuum Fluorescent Displays (VFDs), provides required and supplemental driver information for the 1985 Chrysler H-body series of vehicles. The display cluster features a non-volatile odometer that can be preset, and contains a self-diagnostic capability that conveys information to a service technician.

Under control of a single-chip, 8-bit microcomputer, several VFDs provide the vehicle operator with speedometer, odometer, trip odometer and tachometer readings, as well as the displays for oil pressure, vehicle system voltage, engine coolant temperature, and fuel level. The microcomputer (Motorola MC 6805R3) has internal analog-to-digital converters that eliminate the need for

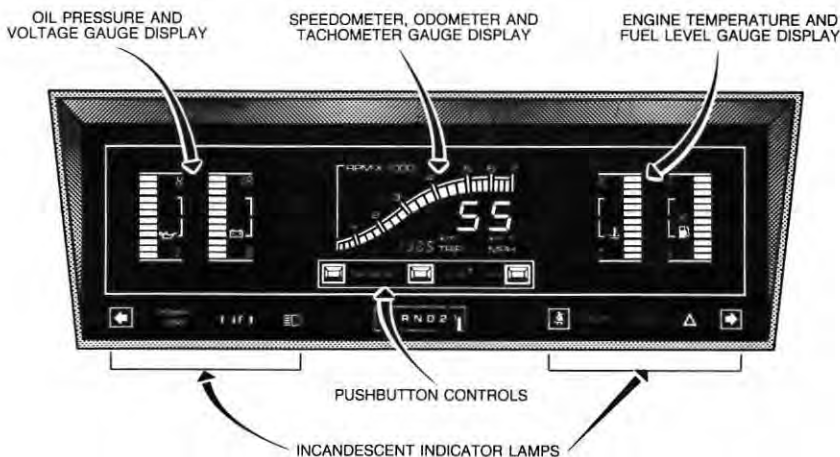

separate converters for each of the system parameters displayed.

Substituting electronics for the standard mechanical cluster technology provided an opportunity for innovative automotive engineering and required new approaches in areas of design, systems requirements, and aesthetics.

Display system

The electronic display portion of the instrument cluster is activated whenever the ignition switch is turned on. Maximum filtered brightness of the VF display's activated segments is approximately 120 foot-lamberts, sufficient

by Gary A. Long, Chrysler Corp.
and Hugo Korn, Motorola Inc.

VACUUM FLUORESCENT DISPLAY

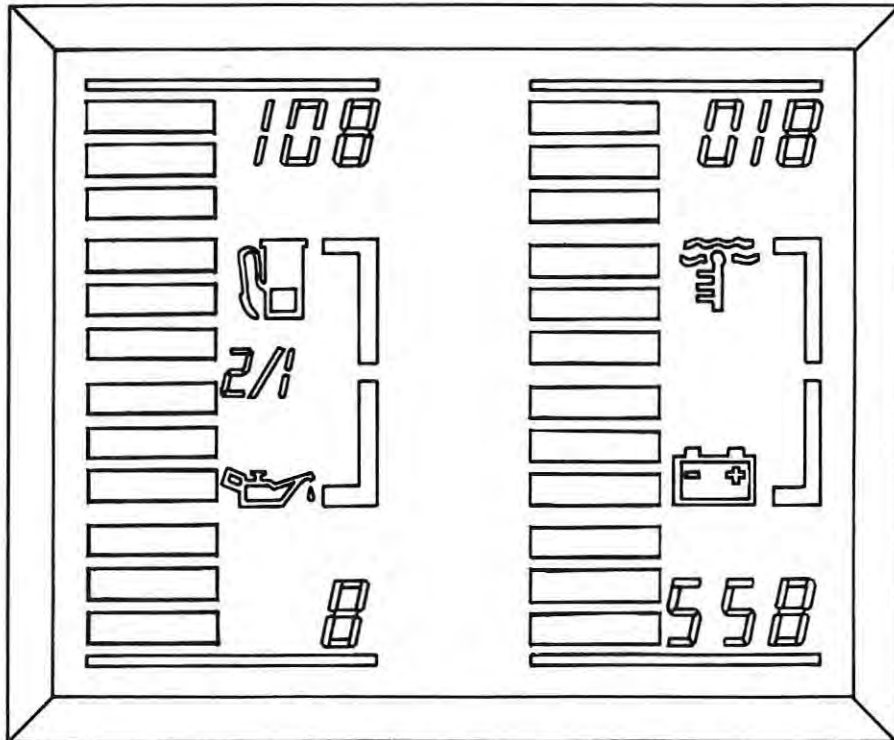

for daytime operation. Four 1½ W wedge-base incandescent lamps illuminate the face of the instrument cluster for nighttime use.

All system gauges are 12-segment bargraphs that display information in a blue-green color when the system is activated. An auxiliary sensor causes the ISO symbol, used to designate a particular display feature, to flash at 1 sec intervals when a predetermined critical value is reached. When the particular function returns to normal, the ISO symbol stops flashing.

- **Oil pressure**—indicates pressures between (approximately) zero and 110 psi (760 kPa). Fixed indices, between high pressure (H) and low pressure (L) notations, denote the normal range of operation. Engine oil pressure display is updated at least four times every three seconds.

- **System voltmeter**—indicates voltages between 8 and 18 volts. Normal range of operation between 11.2 and 16v is depicted by the same type of indices as for the oil gauge. The voltmeter display is updated once each second. If the system voltage decreases to a critical level, the instrument cluster automatically assumes an ignition OFF condition.

- **Engine coolant temperature**—shares VFD with the gauge. Engine coolant gauge operates between 140F (60C) and 260F (127C). For the fuel level gauge—all twelve segments are activated with full, 14 gal (53 liters) capacity. When the level drops to 2.7 gal (10 liters), only two segments remain activated and the ISO fuel symbol begins flashing.

- **Speedometer**—consists of 2½ digits updated every 450 milliseconds.

- **Odometer**—consists of 5½ digits capable of displaying any value from 0 to 199,999, with an asterisk appearing when the value exceeds 199,999. Tenths of miles or kilometers are not displayed as part of the odometer reading. The trip odometer is capable of displaying any distance from zero to 2,480 mi (4,000 km).

- **Tachometer**—This is a 24-segment, ramp type, bargraph wherein each segment represents increments of 250 RPM. Every fourth segment is colored yellow and defines 1,000 RPM increments. A corresponding numerical value is located above each 1,000 RPM segment to identify it. The display is updated every 300 milliseconds at and below the 1,000 RPM point, and every 120 milliseconds above that value.

- **Feature modes**—three pushbuttons, located below the center VF display, permit the driver to place the cluster features in varying modes:

- Convert units, English/metric,
- Display either odometer or trip odometer information,
- Reset trip odometer,
- Start self diagnostic test, and
- Accept odometer present data.

- **Gear selector**—indicator for automatic gear selector (PRNDL) is located beneath the pushbuttons.

- **Warning indicators**—various indicator and warning lamps, illuminated by incandescent bulbs, are located on each side of PRNDL indicator. These include: turn signals, high-beams, fasten seat belt indicator, fuel pacer lamp (with manual transmissions), brake indicator lamp, engine lamp in conjunction with oil pressure and engine coolant temperature functions, and power loss lamp.

Special features

A cluster, self-diagnostic testing function is designed into the system to assist service technicians to verify the integrity of the entire unit. The diagnostic mode is activated using two of the three pushbuttons on the front of the cluster.

The test has three separate steps, all performed in sequential order:

- The first checks the internal operation of the microprocessor and the non-volatile memory (NVM) devices. An internal software routine tests the CPU, ROM, RAM, NVM, and the analog-to-digital converters. If the instrument cluster is completely operative, it will automatically proceed to the next test.

- In this test, all the VF display segments will activate to expose any open segments or display-driver circuitry malfunctions.

- The last test checks for shorted VF displays through sequential activation of all the segments in each of the VF displays.

Any of these tests can be repeated by depressing the "trip reset" button. This self-diagnostic feature is not a comprehensive diagnostic test, but it is intended to provide the service technician a means to determine whether a malfunction is in the cluster, or in the surrounding system—such as the sensors or vehicle wiring.

An Electronic Fuel Injection (EFI) diagnostic feature alerts a service technician through the "Power Loss" lamp in the instrument cluster. Once the interface between the EFI module and the cluster is initialized, the "Power Loss" lamp will automatically flash appropriate codes to assist in diagnosing malfunctions in the EFI system.

An odometer preset mode, under control of a software routine, is designed into every new cluster. This permits a service technician to program the accumulated distance stored in the odometer of the original cluster into the odometer circuitry of a replacement unit. Once information is correctly programmed into the new cluster, the preset software is permanently aborted to prevent tampering.

System circuitry

The bargraph-type displays are unique in that one display pair can be used for all four functions. Since the number of segments used for each bargraph display is relatively few, these displays are directly driven. Each anode to be activated is energized only when it is to be lit, and the grid is not utilized in determining whether the segment is lit or not. This method of driving the displays required the same number of connections as there are segments to be activated.

The odometer/speedometer/tachometer display, however, has 113 discrete segments. For this display, use is made of a time-sharing, or multiplex technique, to reduce the number of connections.

Several segments are connected in parallel and energized simultaneously. Conduction to this group of segments is under the control of several grids. Even though an anode may be energized, the segment will not light up unless the controlling grid permits it. In this way, the number of required connections to the display was substantially reduced—an important consideration as the complexity of the cluster increased.

Displays are dimmed, for nighttime operation, by reducing the "ON" time of the pulse width modulated excitation provided by the driving circuitry. The desired VF display intensity level is controlled by a rheostat on the instrument panel in the vehicle.

Design challenges

One of the major problems designers had to overcome was that of heat generated within the cluster. Maximum power input into the cluster, most of which dissipates as heat, is over 40v. This heat must be removed from the assembly to permit components to operate within specifications.

Primary sources of heat generated in the electronic cluster are the power transistors that serve as switches in the power supplies required to develop the higher voltages for the anodes of the displays. To overcome this problem, the power transistors were mounted on heat sinks, which protrude through the rear of the housing, providing maximum cooling and lowering base heat temperatures.

Another problem the designers faced was in preventing light leakage from one bulb compartment to another in the warning and indicator lamp array. Any form of seal would have resulted in limited air circulation required to cool the bulbs. The solution was to make a two-

part mask. That portion of the mask enclosing the bulbs was changed to a polyester resin material that would not deform when exposed to the operating temperatures. All electronic components were mounted on two circuit boards, one of which serves as a mounting for the displays. When the display pins are soldered into the circuit boards, the display cluster is securely mounted.

And, finally, operation of the VF displays requires higher voltages than those available from the vehicle's electrical system.

This problem was solved by using a switching type power supply in which vehicle DC voltage is converted to the required high DC voltages and AC supply for the filament.

(This article was developed from "An Automotive Electronic Instrument Cluster with a Programmable Non-Volatile Odometer," by Gary A. Long, Chrysler Corp., and Hugo Korn, Motorola Inc., Copyright 1984, Society of Automotive Engineers Inc. - SP565: Electronic Displays and Information Systems, Paper No. 840151.)

Celco
YOKES

for the
Best
CRT Displays

70 Constantine Drive
Mahwah, NJ 07430

I'm interested in the Best Yoke for my CRT Display for best:

Resolution Geometry Settling Sensitivity Convergence

Repeatability Small Size/Light Weight _____

My Application is _____

Please send free CELCO YOKE Selection Guide.

NAME _____ TITLE _____

COMPANY _____

STREET _____

CITY _____

STATE _____ ZIP _____ PHONE () _____ - _____ EXT _____

Please fill in address (or attach business card) and mail to CELCO in company envelope.

Cold Cathode tubes backlight two-color LCD instrument panel

Liquid crystal displays provide a number of features that make them particularly suited for electronic automotive instrument panels, including: high-degree of freedom in display pattern, simple and thin construction, light weight, and low-voltage drive. But, because they are passive devices, LCDs generally are inferior in appearance and quality of display when compared to emissive devices such as vacuum fluorescent displays or light emitting diodes.

These inherent problems were overcome by optimizing the design of each component. White light, cold cathode discharge tubes were used to back illuminate the panel. Blue dye was added to the twisted nematic liquid crystal panels to enhance the quality of background. And, two dye polarizers were attached to the panel enabling the display of two colors on a single

The resultant display system, developed for the Nissan Cedric and Laurel models of its 1984 line of automobiles, provides good visibility, high-quality appearance, fast display response time (less than 0.1 sec at -30C), and two-toned display.

• **Lighting and display**—Three methods were evaluated: reflective, in which the LCD panel is illuminated solely by a reflected light of exterior source; transparent, in which the LCD is illuminated by a light penetrating from the panel's back; and transreflective, having both a reflective and a transparent surface. Negative and positive display were considered using each type of lighting.

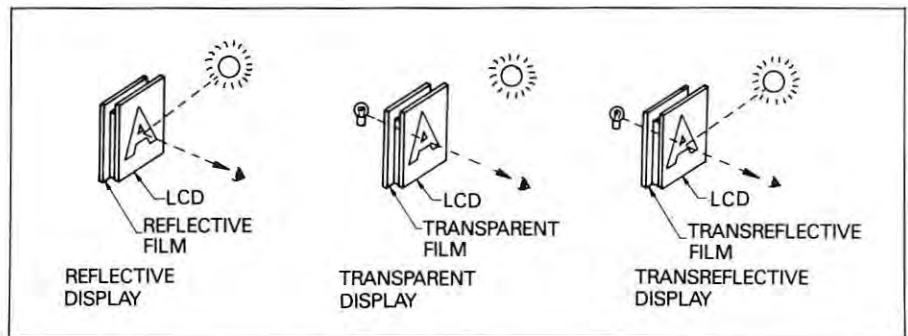

Studies indicated that a transparent type negative display was the most suitable method for automotive display, since it provided good visibility and high-quality appearance. Additionally, it was determined that quality black was preferable for the background. The transreflective type of negative display proved to be the second most suitable method.

• **Color Panel**—To assure that the use of a black background for the negative display would provide proper transmissivity of light from the display elements required that the system's polarizers have a high polarization ratio as well as high transmissivity.

Evaluation of 10 different polarizers resulted in the selection of one having a polarization ratio of 98% and transmissivity of 27%, as the most suitable. A slight amount of blue dye of anthraquinone was added to the liquid crystal layer to remove the green-tone of the polarizer and obtain quality black background.

• **Lighting of panel**—Evaluation of various white lighting illumination resulted in selection of a cold cathode discharge tube that provides high brightness in a small size. To sharpen the contrast between the white display

of the segment (transparent portion) and the background of negative display, the fluorescent screen of the cathode tube was made to produce slightly blue luminescence. The resulting panel display contrast was greater than 1:20.

Controlling stability of back lighting over a wide range required development of a new luminance control circuit, in which the driver voltage waveforms for the cathode tubes are controlled by a synchronous duty-control system. The tubes are driven at 40 kHz through 45 kHz to improve their lighting performance at low temperatures.

Because illumination brightness drops at low temperatures with cold cathode discharge tubes, several heating devices were studied. A heat retaining structure, using a closed resin case, was chosen. Electric noise produced by the cathode tubes (which are driven by approximately 200 v AC) broke the LCD driver circuits, causing erroneous operation of other electrical devices. This problem was solved by grounding one end of the transparent conductive film on the LCD panel glass substrates.

• **Display of color**—To enhance the display's applications, two colors are displayed on a single segment for various warning display indicators—from

by Shigeru Okabayashi, and others,
Nissan Motor Co.

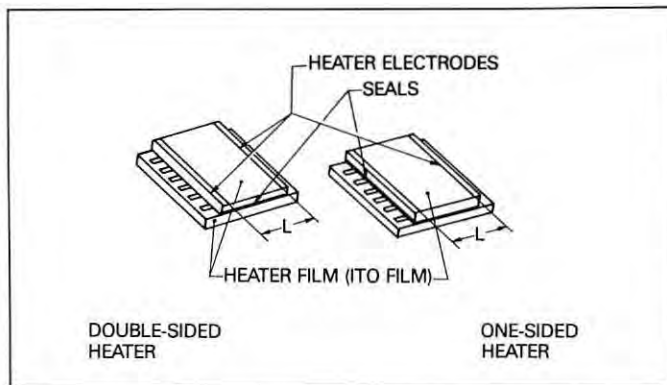
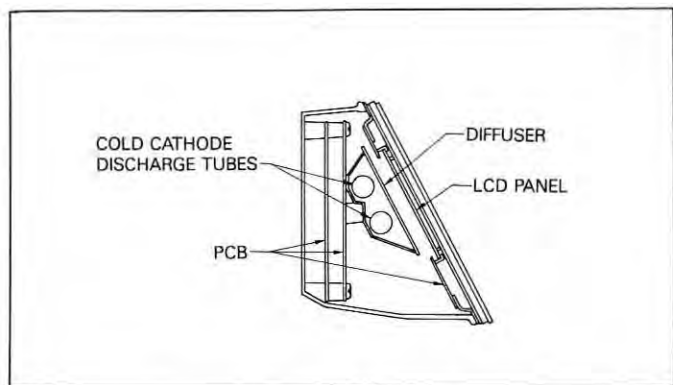

safe through dangerous zones. The two tones were achieved by pasting to the back of the LCD two types of dye polarizers, red and green, so that their directions of polarization intersect at right angles. A neutral polarizer adhered to the panel front is placed parallel with the green polarizer's direction of polarization. The system then displays green if voltage is not applied to the LCD panel, and red if it is applied.

• **Control of temperature**—Achievement of satisfactory display

responsivity at low temperatures required the development of a compensation heater that produced a display response time less than 0.1 sec at -30C, and provided greater heating efficiency responsive to low power consumption. In addition, the heating films had to be transparent to assure maintenance of the LCD panel's transreflective nature.

Two types of heaters were developed: one with heating films on the front and back of the LCD panel; and the other, with a heating film on only one

side of it. Power for heaters is supplied by the vehicle battery. A small, flat thermistor attached to the LCD panel glass substrate senses temperature and passes a current through the heater only when the LCD panel is at a low temperature.

(This article was developed from "New Automotive Applications for Liquid Crystal Displays," by Shigeru Okabayashi, Hiroyuki Nomura, Masahiro Adachi, Hiroshi Kawata, and Satoshi Tanimoto, Nissan Motor Co. Ltd, Copyright 1984, Society of Automotive Engineers - SP-565: Paper No. 840144).

Navigational feature at heart of CRT information center

An interactive CRT vehicle information center, designed for the Continental CONCEPT 100 vehicle, displays a variety of automotive features on a single device—simply by touching the CRT screen.

The TRIPMONITOR system, as it is called, provides information on time (time of day, date and month), trip (fuel economy, trip odometer, and distance-

to-destination), vehicle servicing (status of car systems, including tire pressures and maintenance schedule), EATC system (interior set temperature and mode), and navigation (vehicle heading, map display with vehicle tracking, and vehicle positioning).

System Components

The TRIPMONITOR consists of six major components:

• **CRT monitor**—a large screen display having high resolution for quali-

ty graphics and rugged design to withstand the automotive environment. Color was preferred for increased feature presentation flexibility.

An off-the-shelf, high resolution RGB monitor with 23-cm diagonal screen proved to be rugged enough for automobile use. But, its chassis was so large it posed a packaging problem. The location chosen for the CRT system was only able to accommodate the monitor, with the rest of the system's electronics remotely located from the screen.

*by Mark W. Jarvis and Richard C. Berry
Ford Motor Co.*

Do the instruments meet lighting specs?

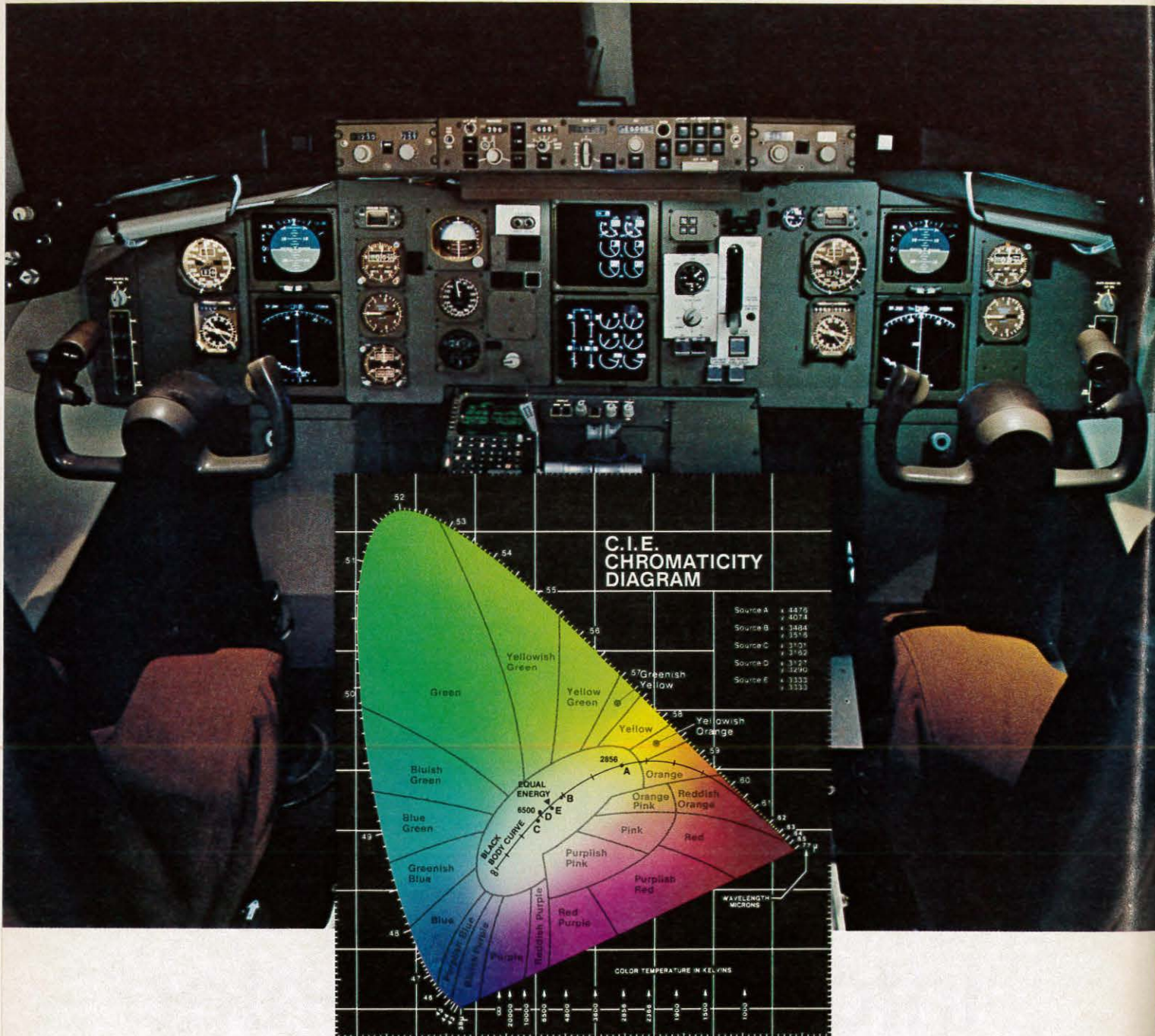

We can tell you in seconds.

High technology instrumentation for spectroradiometry, photometry and colorimetry:
Pritchard® spectral and spatial scanning SpectraRadiometer™ systems.
SpectraScan™ fast spectral scanning SpectraRadiometer systems.

PHOTO RESEARCH

The Light Measurement People

Division of Kollmorgen Corporation

3000 No. Hollywood Way, Burbank, CA 91505 Telephone (818) 843-6100 - Telex 69-1427

AUSTRALIA ETP PTY LTD., Ph: 858-5122, 858-5200 • CANADA OPTIKON CORPORATION, Ph: 519-885-2551 • FRANCE MICRO GISCO, Ph: 670-1158 • HOLLAND INTECHMIJ BV, Ph: 020-56-96-611 • WEST GERMANY OPTIMA VIERTRIEB, Ph: (02122) 67352 • JAPAN KYOKKO TRADING COMPANY, Ph: 03-586-5251 • U.K. MILLECROON INSTRUMENTS LTD., Ph: 207-4844 • INDIA PHOTONICS INTERNATIONAL, Ph: 366665 • ISRAEL DELTA FILM LTD., Ph: 052-55722 • SWEDEN SAVEN AB, Ph: 315-80 • EUROPEAN HEADQUARTERS LUZERN, SWITZERLAND, PHOTO RESEARCH, Ph: 041-4690-89

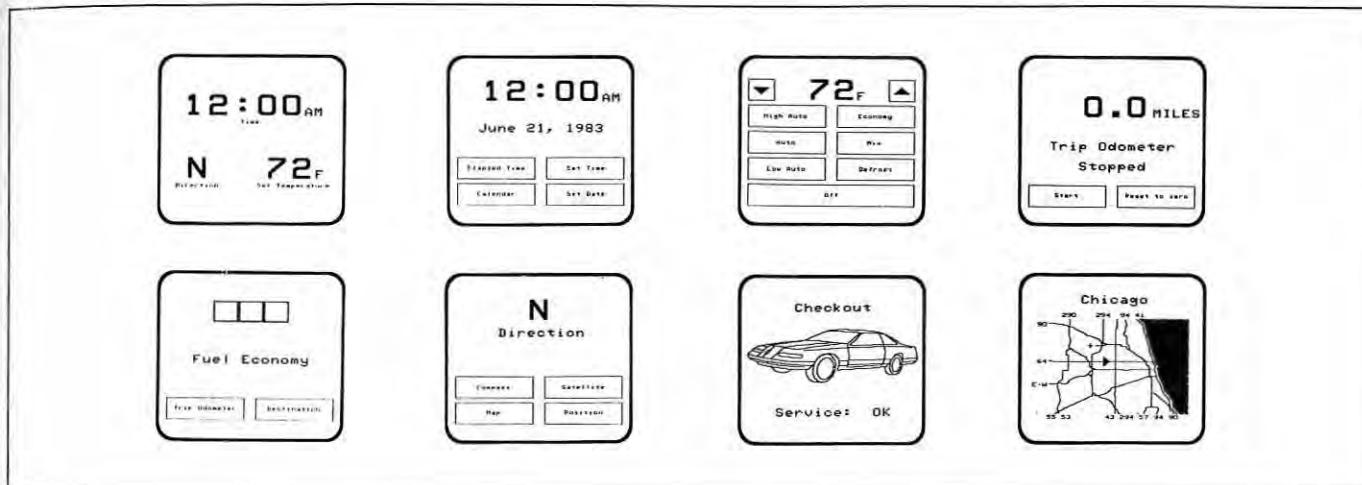

● **Touchscreen/feature controls**—operating and controlling a multiple feature display posed its own set of problems. For each feature and control to have its own select switch, the number of switches would have overwhelmed the driver. And assigning multiple uses to single switches, to reduce the overall number required, would have made it difficult for the driver to remember all of the functions performed by a switch.

A scheme was developed based on an adaptation of that used in military aircraft displays. Using a "programmable label" concept to reduce the number of switches required, areas on the CRT display screen were designated to serve as switch labels that can be easily changed or programmed to represent different tasks as required.

Labels displayed on the screen represent current functions. The TRIPMONITOR touchscreen has ten large rectangular switch areas, with labels displayed on the screen located to coincide with the transparent touchscreen switch area. The vehicle operator simply touches a label to select the function.

In addition to the touch screen, a row of nonprogrammable switches located along the bottom of the display serve as permanent feature category selection switches, (such as SUM, TIME, TRIP, and so on). They may be thought of as a "menu" of feature selections, always available and in view. Whenever a button is depressed, on-screen labels for other related features appear. A touch to that particular label will then display that feature.

● **Navigation system**—One of the major problems confronting development of the system was providing an accurate location-sensing or tracking system for placing the cursor on the display representing a geographic area. Most compass-based systems are subject to errors due to magnetic field aberrations found in vehicles and road systems, as well as magnetic variation from location to location. While some of these sources of error can be compensated through software and calibration techniques, accumulated errors readily become apparent after the vehicle travels a long distance.

Although a dead-reckoning navigational system was chosen as the vehicle's primary location detection method, periodic accurate position updates are provided from a non-driver source—transit navigation satellites. A dead-reckoning algorithm was used, based on vehicle speed, flux-gate magnetic compass information, and software compensation for magnetic variation. The flux-gate compass was mounted behind the rear seat of the vehicle away from changing magnetic fields and a VHF blade-type antenna was mounted on the trunk lid for line of site reception of transit receiver signals.

To obtain precise periodic position updates from a navigation satellite, a commercial transit receiver mounted in the vehicle precisely calculates the vehicle's position based on the satellite's message, data on vehicle travel during the satellite pass, and measurement of the characteristics of received signals—as the satellite approaches, passes, and

recedes. The display system's CRT-drawn map provides an accurate alignment of the vehicle cursor with the portrayed road system.

● **Sensor environment**—When many features are grouped into one system, the sensor environment becomes large. Solving this problem required a distributed approach to sensor interfacing. Most sensor information in the TRIPMONITOR is buffered or processed from another electronic system to reduce the burden on the STD bus controller and thus avoid redundant processing. This distributed approach to sensor interfacing permitted a flexible implementation of features.

● **EATC system**—An Electronic Automatic Temperature Control (EATC) system was incorporated into the TRIPMONITOR to illustrate potential benefits that might result from grouping features into a single display. EATC switches and display were eliminated from the console area with control being performed by the TRIPMONITOR. (EATC senses interior air temperature and controls five plenum doors to regulate the selected temperature in the vehicle.)

Graphics Software

In the development of any software system, a modular program structure is the key factor determining ease of program enhancement and maintenance. Large programs are generally complex and, if not divided into smaller segments, prove difficult to modify. Identification of these segments with the required inputs and outputs repre-

HOW DO YOU KEEP UP WITH THE FASTEST MOVING TECHNOLOGY AROUND?

Attend the 2nd Annual, International
Electronic Imaging Exposition & Conference



How do you stay abreast of the fastest moving technology around? No problem. Just spend a few enlightening hours at Electronic Imaging 85 — the only annual conference to concentrate on the all-important visual techniques that interface man with machine.

Come see the latest and best in this \$27 billion industry, and enhance your image of the dozens of major disciplines involved.

See displays and attend professional papers (sponsored by the Institute for Graphic Communication) on a wide variety of topics, such as: Professional & Engineering Workstations; Electronic Communicating Copiers; Optical & Videodisk; Electronic Printing & Publishing; Intelligent Vision; Computerized Slide Making; Direct Broadcast Satellite; Videotex & Teletext; Photo Sensors—Visible, Infrared, Pyroelectric, X-ray, UV-Sensors; Image Processing; Displays & Hard Copy Output; Digital Fac-

simile; High Definition Television; Electronic Photography; Scientific Applications; Medical Imaging; Graphic Arts; Video Teleconferencing; Computer Graphics; Fiberoptics; Optical Memories; Laser Printers.

Produced by MG Expositions Group, Conference organized by The Institute for Graphic Communication. Sponsored by *digital design* magazine and The Society of Photographic Scientists and Engineers.

MG Expositions Group 1050 Commonwealth Ave.
Boston, MA 02215 617-232-EXPO or 1-800-223-7126

ELECTRONIC 85
IMAGING 85
International Electronic Imaging Exposition & Conference

SHERATON-BOSTON HOTEL • BOSTON, MA • OCTOBER 8-10, 1985

Send today for your Free Pre-Registration Form

sented the first task in developing the graphics software, with emphasis on information flow and modularity of foremost concern.

Every CRT display screen (page) in the TRIPMONITOR is assigned a unique display code that is used by the software to determine the required graphics operations. Attached to each page are up to three subroutines that initiate changes in the refresh buffer contents and include static display updates, dynamic display updates, and touchscreen switch action procedures.

Some of the graphics images displayed on the TRIPMONITOR were generated using a desktop computer, while other graphics elements were made by simple dot plotting or by a digitizing video system. Map images were developed with the aid of a digitizing tablet and graphics software. (Future map images development would begin with databases that contained organized numerical information.)

Human Factors

Human factors received considerable emphasis in the design of the TRIPMONITOR. A CRT in a vehicle is a new phenomenon and every effort was made to make a smooth technological transition from concept to real-world implementation.

These considerations fell into two basic categories: placement and feature design.

- **Placement**—The CRT was placed in the center console area of the vehicle, slightly angled toward the driver and level with the instrument cluster, providing an easy reach to the CRT system controls and an easily viewable display. Proximity of the instrument cluster and CRT display allows a brief glance when shifting attention from one to the other.

- **Feature controls**—By grouping features to be displayed and controlled by one system, the driver's search for information is limited to a single location. The row of feature select switches

along the bottom of the CRT and the touchscreen overlay permit quick easy selection and control of specific features. The switches serve as a main menu, allowing a driver to quickly recover from getting lost in the feature selection process by easily returning to the initial feature level.

The successful development of an automotive CRT system depends on many factors. Technology and hardware must be suitable for the automotive environment; a structured approach to the software design is necessary to develop a graphics system able to handle the processing and display tasks required by the feature design; and human factors should dominate the feature behavior and system operating design.

(This article was prepared from "Cathode-Ray Tube Information Center with Automotive Navigation," by Mark W. Jarvis and Richard C. Berry, Ford Motor Co., Copyright 1984, Society of Automotive Engineers Inc., SP-565, Electronic Displays and Information Systems, Paper No. 840313.)

AD-MU SHIELDING DOES ENHANCE EMI SENSITIVE COLOR DISPLAYS FOR



Achieve high quality hues and sharper color definition for avionics, computer graphics, medical instrumentation, military and other critical color image applications.

A properly selected shielding alloy... placed around or adjacent to a circuit component... suppresses radiated magnetic fields interfering with other nearby components, or vice versa.

That's how AD-MU shielding alloys solve your problem.

56 pages of this 84-page Procurement Catalog/Engineering Manual contains useful technical data covering the entire magnetic shielding field; 28 pages consist of usual catalog type data.

Just request this vital helpful data on your letterhead and it's yours.



AD-VANCE MAGNETICS, INC.

625 MONROE STREET, ROCHESTER, INDIANA 46975

(219) 223-ADMU TWX 810 290 0294

The Problem Solving Magnetic Shielding Specialists—4 Decades of Magnetic Shielding Leadership

CRT system creates, displays road maps to navigate autos

While most automobile manufacturers, over the past few years, have been exhibiting electronic navigational systems in "concept cars" (see p. 21), or developing such devices for installation in near-future vehicles, a small California electronics firm appears to have taken a quantum lead with the introduction this summer of a functional CRT automotive navigation display.

The ETAK Navigator, as it is called, is a self-contained information display system that uses "augmented dead-reckoning" to determine a vehicle's position solely by means of a compass, motion sensors, a computer, and a map database.

Key to this easy-to-use system is its moving map display. As the vehicle travels, its position on the CRT screen, marked by a small triangular cursor, remains constant. It's the map that moves around the cursor to coincide with the real world immediately outside the vehicle.

The system's electronic maps are not simply displayed in a fixed form. Instead, as the vehicle moves, the maps are continuously created and recreated (through a software graphics program) on the screen once every second. Each map is modified by the computer, according to the vehicle's changing position and the operator's desire for particular information, to show the surroundings changing just as they occur.

The map database, supplied by a series of map cassettes called Etak-Maps, displays basic street and road information in extensive detail... down to individual addresses.



Map Index



Display with Destination

Twelve function buttons, located around the screen perimeter, permit selection of specific views of the vehicle's position or surroundings. At the touch of a button, the operator can zoom-in for a detailed closeup of the vehicle's position, with all streets displayed and labelled. By depressing another button, the operator can zoom-out for a less detailed overview of major streets. The screen's zoom level varies from 1/4 mi to 4000 mi, which shows the national interstate system map.

When the vehicle is stopped, depressing the "North-Up" button fixes the electronic map in the conventional orientation of paper maps and returns it to "Heading-Up" orientation with a second touch.

By scrolling through the system's

map index, an operator can select and display one or a number of destinations. A selected destination appears as a flashing star, with the distance from the vehicle's current location displayed on the screen.

The Etak Navigator consists of four basic components, none of which require modification of the vehicle for installation and operation:

- **Vector-graphic display** - (1024 x 770 resolution) in two sizes—Model 450, a 4 1/2" screen with a flexible mounting for passenger cars, and Model 700, a 7" screen for commercial applications. Both models are equipped with automatic brightness control and an anti-glare filter (mounted on brackets off the dashboard).

- **Compact tape drive**, which uses 1/4-in. magnetic tape cassettes operating at 80 ips, each containing every street and specific address, for an area about twice that of an ordinary paper street map, as well as overviews of major state and regional roads, and national interstates (installed under the vehicle dashboard or in the glove compartment).

- **Electronic package** - containing the computer, display drives, and tape interface (installed under a seat or in the trunk).

- **Navigational sensors and electronic compass**, which is computer corrected for magnetic effects of the vehicle (sensors are mounted near the wheels, the compass in any inconspicuous location in the vehicle).

Prices: Model 450, \$1395; Model 700, \$1595; EtakMap cassettes, \$35 each. ETAK Inc., 1287 Lawrence Station Rd., Sunnyvale, CA 94089 (408/747-1903).

Graphics controllers/display

Two plug-in, high-speed graphic controllers capable of drawing images at 1 million pixels per second, are compatible with the IBM PC AT, PC XT and the PC Expansion Unit. Drawing speed is generated by a proprietary two-micron CMOS graphics controller chip set with an on-board Motorola 68000 CPU. A 60 Hz, non-interlaced RGB display, CD-1, with 640 x 480 resolution operates with the controllers. The M-16 and M-256 controllers provide 16 and 256 colors respectively from a palette of 4,096. Prices: \$2,250 and \$2,850, respectively.

VERTICOM INC., Sunnyvale, CA 408/747-1222

Flat panel touch-input display

The VuePoint II touch interactive, flat-panel display is a 12-line by 40-character gas plasma device that develops up to 480 clear, bright orange or green alphanumeric characters on a black background for maximum visibility. The panel is coupled with a 12-line by 20-column optical "touch" screen with up to 240 high-resolution "touch" points. The system's standard 3-page display memory is

expandable to 7, 19, 35, or 51 pages. Smart system features include: multiple touch response formats, auto-scroll, protected fields, multiple blink rates, dual intensity and random cursor positioning, all under user control. The system has a compact design and small footprint (9 in. x 12 in. x 4 in. deep), and comes with an RS-232C interface. Optional enhanced communications modules accommodate RS-422, 423, 485, 20mA, TTL and other serials and parallel communication protocols.

GENERAL DIGITAL CORP., E. Hartford, CT 203/528-9041

Low-profile LED lamp

A T-1, 3/4-in. (5mm) LED lamp, in a choice of three diffused colors, features a low profile package with a .295-inch-high flangeless lens. The series includes: LDR 1201, red LED with 1.0 minimum Mcd at 20 mA; LDG 1251, green LED with a 2.5 minimum Mcd at 20 mA; and LDY 1231, yellow LED with 1.0 minimum Mcd at 20 mA. Other features include a wide viewing angle of 70 deg, 1-inch leads with no standoffs, and IC com-

patibility. Prices: \$.15 each (quantities of 1000).

SIEMENS COMPONENTS INC., Cupertino, CA 408/257-7910

Video-tracing

The Video Tracing System uses a video camera to project drawings onto a monitor for use with many microcomputer CAD systems, including AutoCAD and CADmaster. Primary applications for the system include tracing over rough or finished existing drawings, X-rays, mapping, and seismic records. Three dimensional objects can be easily traced, either from a photograph, video freeze-frame image, or from the object itself. The basic system includes software, video camera, stand and scan synchronizer card for IBM PC, XT or AT. Cost: under \$5,000.

BRIGHTER IMAGES, Lafayette, CA 415/283-3340

QUALITY GLASS PARTS Laser Scanning Computer Peripherals

- Average Modulus of Rupture 31000 PSI
- No Loss In Dimensional Accuracy



Ioroglas®

AGP
®

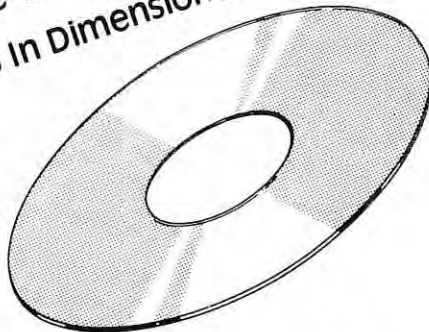

Artistic Glass Products Company
215-536-0333 • TELEX 211089 (AGP UR)

Trumbauersville, PA 18970-0051

TEXAS OPPORTUNITIES

Our client, a premier electronics firm, is currently seeking professionals with experience and training in Information Display.

Manager Information Display Technology

To \$70K

Will direct CRT, Color Graphics, Plasma Display and Interface Technologies for the company. Responsible for Measurement Lab start-up. Individual should be degreed, with private industry experience.

CRT Monitor Engineer To \$50K
Color Graphics Engineer To \$50K
Plasma Display Engineer To \$50K
Display Technology Engineer To \$50K
Information Display Consultant Open

Nimmo Enterprises is an executive search firm which specializes in the high-tech electronics industry. If you have an interest in any of the above positions, please send your resume in complete confidence to:

David Nimmo - President, Nimmo Enterprises, 4420 FM 1960 W., Suite 102, Houston, TX 77068 or call (713) 580-1926.

Our client company is an equal opportunity employer.

PHOTONICS TECHNOLOGY, INC.

PIONEERS AND LEADERS IN THE Design, Development, and Production of AC Gas Discharge Displays

PHOTONICS
TECHNOLOGY
PRESENTS

THE WORLD'S FIRST
METER-SIZE,
HIGH RESOLUTION
FLAT DISPLAY TERMINAL

DEVELOPED FOR
MILITARY PROGRAMS
INCLUDING U.S.ARMY
AFATDS

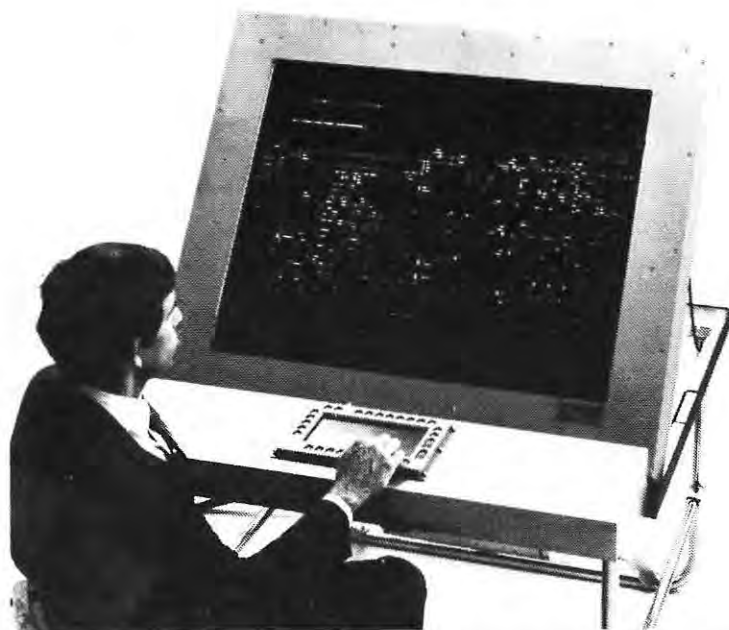

This is the world's first large area, high resolution, non-projected, flat display terminal. Utilizing AC gas discharge plasma display technology, the terminal has an active display matrix of 1600 by 1200 pixels measuring over 39 inches (one meter) diagonally with 5.3 square feet of viewing area and a resolution of 2500 pixels per square inch. All drive electronics are mounted in a 4 inch thick picture frame package around the perimeter of the transparent, thin (0.5 inch) display screen allowing for rear-projected and see-through applications.

Jointly developed by Photonics Technology, Inc., Luckey, Ohio and Magnavox Electronic Systems Co., Ft. Wayne, Indiana.

Photonics and Magnavox are presently completing the development of AC gas discharge flat panel displays ranging in size up to 3 meters with active display matrices up to 4096 by 4096 pixels. Multicolor displays are also being developed.

Photonics is the world's leading developer and manufacturer of sophisticated, high technology AC gas discharge displays. We are able to design and manufacture flat display panels, monitors, and/or terminals in a variety of sizes at relatively low costs. Our flat displays range in size from a few centimeters up to one meter. Some of our standard and custom displays include the following:

Panel Size, Pixels	Resolution, Pixels Per Linear Inch
128 x 256	40, 60
128 x 512	60
256 x 256	60
256 x 512	64
512 x 512	60, 64, 73, 83
512 x 1024	60
1024 x 1024	60, 73, 83
1200 x 1600	50.8, 101

Our standard display resolution ranges from 30 to 100 pixels per linear inch (900 to 10,000 pixels per square inch). Display resolutions up to 200 pixels per linear inch are available.

For Further Information, Contact:

Donald K. Wedding Sr., VP Marketing Photonics Technology, Inc., P.O. Box 432, Luckey, Ohio 43443, 419-666-0033.
Research, Development, and Manufacturing facilities located at 6967 Wales Road, Northwood, Ohio 43619.

(... continued from p. 14)

Thin cathode tube

the project continued under Kaiser's guidance with Navy and Army money, and—as it turned out—quite a bit of Kaiser money. We set up a lab in Palo Alto, CA, with work proceeding simultaneously on the tube and the computer system.

Meanwhile, the patent dispute continued. It seems Gabor had indeed invented a tube similar to mine. Although I had invented mine first, he had filed his early on, while I had waited. There were some differences, though. I had "reduced it to practice"—that is, built and operated a tube—while Gabor had not. My patent application also covered a second means of deflecting the electron along an edge of the tube; his was limited to deflection behind the phosphor only.

When the patent decision was finally handed down, I was recognized as the inventor, with the US patent in my name. In England, since whoever files first gets the patent, Gabor got a limited version.

During the tube's development, my research group concentrated on three items: the basic tube and its elements, the tube envelope, and the computer.

The tube envelope was the most difficult item to develop. We could have made a slightly spherical envelope for civilian use, but the Navy required flat tubes. The air pressure amounted to over 1½ tons for a 14-in. square tube, making it most difficult to develop a flat envelope that would withstand a three-to-one safety factor test. Tubes sizes ranged from 5 to 17 in.

The Navy also required the dome tubes to be transparent, while insisting that the display be bright enough for viewing in sunlight. Fortunately, Charles Feldman at the Naval Research Laboratory was working on a transparent phosphor at the time.

The thin CRT and its computer eventually did fly in the jet as planned. It was the precursor of what today is routinely accepted as an instrumentation system.

(This article was adapted from History of Kaiser-Aiken Thin Cathode Ray Tube, W. Ross Aiken, IEEE Transactions on Electron Devices, Vol. ED-31, No. 11, November 1984.)

Video display terminal

ADM 11plus general purpose video display terminal features 16 function keys for 16 programmable and 16 non-programmable functions, and is capable of handling transmissions up to 19,200 baud without handshaking. The terminal also features three edit keys and break key that can be programmed to perform an additional seven

functions. Editing features include character/line insert, character/line delete, line erase, and page erase. Additional features include four visual attributes—non embedded reduced intensity, plus blink, blank, and reverse video. Price: \$695. Lear Siegler, Inc., Data Products Div., 901 E. Ball Rd., Anaheim, CA 92805 (800-LEAR-DPD).

Sperry

in Albuquerque



Try your hand at some revolutionary technology with Sperry's Aerospace & Marine Group, a leading supplier of sophisticated electronics to world aviation. We're looking for **engineers** to work with:

CRT Display Development

We're clearly the leader in the development and production of electronic display systems for aircraft cockpits such as the F-15, F-16, and F-111 fighters and the B1-B bomber. These displays provide crucial information to flight crews quickly and efficiently, in a wide variety of formats and colors. Join us in the following areas:

Electronic Design

BSEE degree and two or more years' experience in analog or digital design required. Some experience with monochrome and/or color CRT systems including display processor or a closely related field is also preferred. Customer interface and proposal experience is also desired.

- High speed digital processing
- Analog-to-digital converters
- Raster/stroke CRT circuitry design

Reap the Rewards

With Sperry, you'll enjoy a competitive salary, generous benefits and a professional, state-of-the-art working environment. Find out more — send your resume and salary history, in confidence, to Brandon Harwood, Sperry, P.O. Box 9200, Albuquerque, NM 87119.



Equal Employment Opportunity/Affirmative Action Employer. U.S. citizenship required.

President's Message

SOCIETY OFFICERS

President: I.F. Chang
Vice President: J.A. van Raalte
Treasurer: L.E. Tannas, Jr.
Secretary: W.F. Goede

PRESIDENT'S ADVISORY COUNCIL

T.V. Curran, A. Kmetz, J. Simonds,
W. Good, B. Lechner, H.G. Slottow,
P. Pleshko

DIRECTORS

Minneapolis/St. Paul: T.J. Werner
Midwest: J. Markin
Delaware Valley: W.G. Mulley
New England: T. Cheek
Mid-Atlantic: P. Pleshko
Bay Area: H. Sherman
Los Angeles: R.C. Knepper
San Diego: R.E. Thoman
Japan: M. Ashikawa
Past President: G.F. Carroll

COMMITTEE CHAIRMEN

Academic: L. Todd, L. Weber
Archives/Historian: R.C. Knepper
Bylaws: A. Silzars
Chapter Formation: A. Lakatos, C.J. Gerritsma
Definitions & Standards: Fred Oess
Group Formation: A. Penz, E. Lean
Honors & Awards: T.C. Maloney
Intersociety: H.L. Funk
Memberships: N. Caswell, K.C. Park
Nominations: G.F. Carroll, TDuPuis, B. Lechner
Proceedings: S. Sherr, C. Land, J.E. Bigelow
Publications: L. Maldoon, P. Ngo
Publicity: D. Pinsky
Symposium Advisory Committee:
J.A. van Raalte, T. Credelle, R. Durbeck

CHAPTER CHAIRMEN

Bay Area: G. Carroll
Delaware Valley: J. Parker
Japan: S. Kobayashi
Los Angeles: K. Kilcoyne
Mid-Atlantic: A. Kmetz
Midwest: J. Markin
Minneapolis/St. Paul: G. White
New England: M. Silverstein
San Diego: A. Dolle
UK & Ireland: M. Green

OFFICE ADMINISTRATION

National Office Mgr: Bettye Burdett

SOCIETY FOR INFORMATION DISPLAY

8055 West Manchester Avenue-Suite 615
Playa Del Rey, CA 90293 - 213/305-4502



I was very pleased and flattered to have received a letter from Mr. W. Ross Aiken, well-known for the Aiken thin CRT, commending SID on the growth it has achieved over the past few years. Ross, who now lives in Maui, Hawaii, was active in the early formative days of SID. In 1967, the society presented him its distinguished Fellow Award for his work on the tube.

The fact that our members living far away from the continental United States take time to write letters to me (I recall receiving letters from Australia) is a sure indication that SID and its publications do reach distant places on this globe.

Recently, Ross published an historical account of the Kaiser-Aiken Thin Cathode-Ray Tube¹ that I am sure would be of interest to many SID members. His paper is a personal account of the Aiken-tube invention process, and Ross' entrepreneurial experiences. I am very delighted that Mr. Aiken has given us permission to extract from his article the "Aiken Story" that appears in our journal this month (see p.).

I have, on occasion, requested in this column that members submit technical articles and recent or historical inventions/patents to me that they might be considered for future publication in our journal. I hope that the "Aiken Story" will encourage other SID members to share their experiences and efforts with ID's readers ... since most inventors probably have found that reviewing details about older inventions often triggers new ideas. This is particularly true in the field of display devices.

Perhaps it would be an interesting exercise to make some comparisons of current flat CRT developments (RCA^{2,3}, Sinclair⁴, Sony⁵, Philips-England^{6,7}, Matsushita⁸) with the Aiken tube to see for yourself how many new ideas were triggered by Aiken.

1. W. Ross Aiken, "History of the Kaiser-Aiken Thin Cathode Ray Tube," IEEE Transactions on Electron Devices, Vol. ED-31, No. 11, November 1984, pp. 1605-1609.
2. W.W. Siekanowicz, T.L. Credelle, F.E. Vacarro and C.H. Anderson, "Ladder Mesh and Slalom Electron Guides for Flat Cathodoluminescent Displays," 1980 SID International Symposium Digest of Technical Papers, Vol. XI, pp. 24-25.
3. T.L. Credelle, C.H. Anderson, F.J. Marlowe, R.A. Gange, J.R. Rields, J.T. Fisher, J.A. van Raalte and S. Bloom, "Cathodoluminescent Flat Panel TV using Electron Beam Guides," 1980 SID International Symposium Digest of Technical Papers, Vol. XI, pp. 26-27.
4. Clive Sinclair, "Small Flat Cathode Ray Tube," 1981 SID International Symposium Digest of Technical Papers, Vol. XII, pp.138-139.
5. K. Smith, "CRT Slims Down for Pocket and Projection TV's," Electronics, July 19,1979, pp. 67-68.
6. A. Woodhead, D. Washington, A. Knapp, J. Mansell and C. Overall, "The Channel Electron Multiplier CRT: Concept, Design and Performance," 1982 SID International Symposium Digest of Technical Papers," Vol. XIII, pp.206-207.
7. D. Washington, J.R. Mansell, D.L. Lamport, A.G. Knapp and A.W. Woodhead, "Progress of the Flat Channel Multiplier CRT," 1985 SID International Symposium Digest of Technical Papers," Vol. XVI, pp.166-169.
8. Masanori Watanabe, Kinzo Nonomura, Minoru Ueda, Takashi Kanehisa, Yuichi Moriyama and Jun Nishida, "A Color Flat-Panel Display Using Matrix Drive and Deflection System," 1985 SID International Symposium Digest of Technical Papers," Vol. XVI, pp. 185-186.

Sustaining Members

Ad-Vance Magnetics, Inc.
625 Monroe St.
Rochester, IN 46975
219/223-3158

AEG-Telefunken Corp.
Rt.22-Orr Dr.
Somerville, NJ 08876
201/722-9800

Amunel Manufacturing Corp.
4737 Darrah St.
Philadelphia, PA 19124
215/535-3000

Asea AB, Dept. YLKHM
S-72183
Vasteras, Sweden
021/10-0000

Audiotronics Corp.
7428 Bellaire Ave.
P.O. Box 3997
No.Hollywood, CA 91609
818/765-2645

Babcock Display Products
1051 S. East St.
Anaheim, CA 92805
714/491-5110

Ball Electronic Systems Div.
P.O. Box 589
Broomfield, CO 80020
303/469-5511

Bendix Corp.
Flight Systems Div.
Teterboro, NJ 07608
201/288-2000

Bidco, Inc.
8 Commercial St.
Hicksville, NY 11801
516/433-0740

Cardion Electronics
Div. of General Signa I Corp.
Long Island Expressway
Woodbury, NY 11797
516/921-7300

Cathodyne Corp.
Sub. of Kloss Video Corp.
490 Windsor Park Dr.
Centerville, OH 45459
513/748-1254

CESCA
Sistemas Electronics, S.A.
APD036, 189
Madrid, Spain
91/675-4300

CELCO
(Constantine Engrg. Labs Co.)
70 Constantine Dr.
Mahwah, NJ 07430
201/327-1123

Cherry Electrical Products Corp.
3600 Sunset Ave.
Waukegan, IL 60085
312/662-9200

Chomerics Inc.
8 Commonwealth Ave.
Woburn, MA 01888
1-800/225-1936

Clifton Precision/Special Devices
5100 State Rd.
Drexel Hill, PA 19026
215/622-1718

Clinton Electronics Corp.
6701 Clinton Rd.
Loves Park, IL 61111
815/633-1444

Conrac Corp.
3 Landmark Sq.
Stamford, CT 06901
203/348-2100

Control Interface Co. Ltd.
Optoelectronics Div.
21 Rt. 10
East Hanover, NJ 07936
201/887-3222

Corning Glass Works
Electronic Materials Dept. MP21-3
Corning, NY 14830
607/974-7451

C.W. Cameron Ltd.
Burnfield Rd.
Giffnock
Glasgow, Scotland
UKG46-7TH

Dale Electronics
P.O. Box 609
Columbus, NE 68601
402/564-3131

Data Images
1283 Algoma Road
Ottawa, Ontario
Canada, K1B3W7

Diehl Research Center
Diehl Corp.
65 Commerce Rd.
Stamford, CT 06902
203/357-1048

Display Components, Inc.
334 Littleton Rd.
Westford, MA 01886
617/692-6000

Dontech Inc.
601 Airport Industrial Blvd.
P.O. Box 889
Doylestown, PA 18901
215/348-5010

Eagle Magnetic Co. Inc.
P.O. Box 24283
Indianapolis, IN 46224
317/297-1030

EG&G Gamma Scientific
3777 Ruffin Rd.
San Diego, CA 92123
619/279-8034

Electro-Plasma, Inc.
4400 Martin-Moline Rd.
Millbury, OH 43447
419/838-7511

Endicott Research Group Inc.
2601 Wayne St.
Endicott, NY 13760
607/754-9187

Ford Aerospace and
Communications Corp.
WDL Div.
3939 Fabian Way
Palo Alto, CA 94303
415/326-4350

Futaba Corp.
629 Oshiba
Mobara, Chiba 297, Japan
0475-24-1111

Garrett Mfg. Ltd.
255 Attwell Dr.
Rexdale, Ontario, Canada M9W 5B8
416/675-1411

GEC Avionics
(Affil. General Electric Co.
p.l.c. of England)
4500 N. Shallowford Rd.
Atlanta, GA 30338
404/394-7800

General Atronics Corp.
Sub. of Magnavox Govt. & Industrial
Electronics Co.
1200 E. Mermaid Lane
Philadelphia, PA 19118
215/233-4100

General Electric Co.
Aerospace Control Systems Dept.
P.O. Box 5000
Binghamton, NY 13902
607/729-2511

GML Information Services
594 Marrett Rd.
Lexington, MA 02173
617/861-0515

Grid Systems Corp.
2535 Garcia Ave.
Mt.View, CA 94043
415/961-4800

GTE
100 Endicott St.
Danvers, MA 01923
617/777-1900

Hartman Systems
A Figgie International Company
360 Wolf Hill Rd.
Huntington Station, NY 11746
516/427-7500

Hoya Optics Inc.
3400 Edison Way
Fremont, CA 94538-6138
415/490-1880

Hughes Aircraft Co.
P.O. Box 1042
ElSegundo, CA 90245
818/391-0711

Hycom, Inc.
16841 Armstrong Ave.
Irvine, CA 92714
714/261-6224

IBM Corp.
Armonk, NY 10504
914/765-1900

Imapro, Inc.
West Royalty Industrial Park
Charlottetown, Prince Edward Island,
Canada C1E 1B0
902/892-8594

Industrial Electronic
Engineers, Inc.
7740 Lermona Ave.
Van Nuys, CA 91405
818/787-0311

Interstate Electronics Corp.
Display Product Operations
1001 E. Ball Rd.
Anaheim, CA 92803
714/635-7210

ISE Electronics Corp.
P.O. Box 46
Ise, Mie, Japan
0596/39-1111

K & R Engrg Sales Corp.
354 Route 206
Flanders, N.J. 07836
201/584-5235

Litton Systems Canada Ltd.z
25 Cityview Dr.
Rexdale, Ontario, Canada M9W 5A7

LXD, Inc.
24500 Highpoint Rd.
Cleveland, OH 44122
216/292-3300

Magnetic Radiation, Inc.
92 N. Lively Blvd.
Elk Grove Village, IL 60007
312/437-5200

Mayertro Industrial Pte. Ltd.
40 Pandan Rd.
Singapore 2260,
Republic of Singapore
2643400

Micro-Curl Display Technology Inc.
61 Wilton Rd.
Westport, CT 06880
203/226-0222

Mitsubishi Electronics America, Inc.
991 Knox St.
Torrance, CA 90502
213/515-3993

NEC Electronics, Inc.
401 Ellis St., PO BOX 7241
Mountain View, CA 94039
415/960-6041

Nederlandse Philips Bedrijven B.V.
PO Box 218
5600MD Eindhoven
The Netherlands
31-40-791111

Norden Division,
United Technologies Corp.
100 Helen St.
Norwalk, CT 06856
203/852-4905

OKI Electric Industry Co., Ltd.
550-5 Higashiasakawa-choHachioji-shi
Toyko, 193, Japan
0426/63-1111

Optical Coating Laboratory, Inc.
2789 North Point Pkwy.
Santa Rosa, CA 95407-7397
707/545-6440

Optical Radiation Corp.
1300 Optical Dr.
Azusa, CA 91702
818/969-3344

Orwin Associates, Inc.
88 Seabro Ave.
Amityville, NY 11701
516/842-7177

Ovonic Display System Inc.
1896 Barrett St.
Troy, MI 48084
313/280-1900

Panelvision Corp.
265 Kappa Dr.
Pittsburgh, PA 15238
412/963-9635

Philips Electronics Ltd.
601 Milner Ave.
Scarborough, Ontario,
Canada M1B 1M8
416/292-5161 Ext.2567

Phosphor Products Co., Ltd.
27 Dawkins Rd., Hamworthy
Poole, Dorset BH154JB, UK
0202-677220

Photo Research Div.
Kollmorgen Corp.
3000 N. Hollywood Way
Burbank, CA 91505
818/843-6100

Photonics Technology
P.O. Box 432
Luckey, OH 43443
419/666-0033

Plessey Displays
Station Road
Addlestone, Weybridge
Surrey KT15 2FW, UK
0932-4782

Plessey Optoelectronics
and Microwave Ltd.
Wood Burcote Way
Towcester, Northants,
England NN127JN
0327-51871

PTK Div., Emerson Electric Co.
1173 Los Olivos Ave.
P.O. Box 6128
Los Osos, CA 93402
805/528-5858

Quantum Data, Inc.
455 E. Kehoe, Suite 104
Carol Stream, IL 60188
312/668-3301

Rank Electronic Tubes Ltd.
Sidcup-By-Pass
Sidcup, Kent, DA14, 6LZ England
01/302-0271

Raytheon Co.
Industrial Components Operation
465 Center St.
Quincy, MA 02169
617/899-8400

RCA Laboratories
David Sarnoff Research Center
Princeton, NJ 08540
609/734-2000

SAI Technology Co.
4060 Sorrento Valley Blvd.
San Diego, CA 92121
619/452-9150

Sanders Associates, Inc.
MER15-1222
C.S. 2035
Nashua, NH 03061
603/885-3522

Chapter Notes

Bay Area: May 21, 1985

Speaker: Jerry Gard, Vice President, Advanced Technology
Kaiser Electronics
San Jose, CA

Topic: New Dimensions in Head-Up Displays (HUD)

HUDs are becoming increasingly popular in military aircraft. In his presentation, Mr. Gard reviewed the fundamentals of the HUD with special emphasis on the state-of-the-art in this new technology represented by so-called "holographic" HUDs.

Mid-Atlantic: May 14, 1985

Speaker: Thomas M. Rice, Consumer Electronics
Eastman Kodak Co.
Rochester, NY

Topic: 8-mm Video Technology

In March 1983, 122 companies from around the world agreed to a standard for a new video format—8-mm video. In January 1984, Eastman Kodak introduced the Kodavision Series 2000 line of products, the world's first hardware utilizing this new 8-mm video standard. In his presentation, Mr. Rice described the technical features and characteristics of the 8-mm standard and compared them to current 1/2-in. systems. He also described and demonstrated the Kodavision Series 2000.

Since joining Kodak in 1966, Rice has been involved as a systems analysis engineer in the development of photographic and electronic systems for both business and consumer use. He was involved in the development of the original camera concept for Kodak's disc camera. Since 1984, Rice has been responsible for the definition and development of 8-mm video products. He is currently department head of the Motion Video Dept.

UK & Ireland Chapter: The first Annual General Meeting of the SID UK & Ireland Chapter will be held at 10:30 am on Tuesday, September 17, 1985, at Standard Telecommunication Laboratories, London Road, Harlow, Essex. The agenda includes confirmation of by-laws, election of officers, and election of committee members among other business. A technical meeting on LCDs will follow the business meeting.

SID in Europe:

In 1984, a very positive response by SID members in Europe (to form a new chapter) resulted in the UK & Ireland Chapter. Until such time as additional chapters are formed, all European members are considered to be part of the UK Chapter.

A European steering committee under the chairmanship of Tuomo Suntola, Lohja Corp., Finland, meets two or three times a year to assist in tackling problems of SID chapter formation, and to present a European view to the SID main board. Until other European national or regional chapters are formed, information concerning the UK & Ireland Chapter is sent to six SID correspondents in Europe who then distribute this information to local members, thus circulating news of the UK activities to all European SID members.—*Alfred Woodhead, European Representative, Philips Research Laboratory, Redhill.*

IEE Awards:

Three SID members shared the "Institution Premium" award, presented by the Institution of Electrical Engineers, for papers they presented on Flat Cathode-Ray Tubes last year: Darek Washington and Alfred Woodhead, along with some of their Philips Research Labs colleagues; and Daphne Lamport.

Singer-Librascope
Aerospace & Marine Systems Group
833 Sonora Ave.
Glendale, CA 91201
818/245-8711

Sony Corp.
7-35 Kitashinagawa 6-chome
Shinagawa-ku Tokyo, 141 Japan
03/493-3406

Stanford Resources, Inc.
P.O. Box 20324
San Jose, CA 95160
408/448-4440

Sun-Flex Co., Inc.
20 Pimentel Court
Novato, CA 94947
415/883-1221

Syntronic Instruments, Inc.
100 Industrial Rd.
Addison, IL 60101
312/543-6444

Tektronix, Inc.
Information Display Products
P.O. Box 500
Beaverton, OR 97007
503/644-0161

Telmos, Inc.
740 Kifer Rd.
Sunnyvale, CA 94086
408/732-4882

Texas Instruments, Inc.
P.O. Box 225936, MS105
Dallas, TX 75265
214/238-4533

Thomas Electronics, Inc.
100 Riverview Dr.
Wayne, NJ 07470
201/696-5200

Thomson-CSF Components
Dumont Div.
550 Mount Pleasant Ave.
Dover, NJ 07801
201/328-1400

Thorn-Emi Brimar Ltd.
Greenside Way Middleton,
Manchester M24 1SN England
061/681-7072

Triumph-Adler AG
Further Str. 212
8500 Nurnberg, W. Germany
0911/322-0

UCE Liquid Crystal Displays
24 Fitch St.
Norwalk, CT 06855
203/838-7509

Venus Scientific Inc.
399 Smith St.
Farmingdale, NY 11735
516/293-4100

Westinghouse Electric Corp.
Industrial & Government Tube Div.
Westinghouse Circle,
Horseheads, NY 14845
607/796-3350

Zenith Electronics Corp.
1000 Milwaukee Ave.
Glenview, IL 60025
312/391-7657

HUMAN FACTORS SOCIETY

29th Annual Meeting
September 29 — October 3, 1985

- Communications
- Training
- Environmental Design
- Organizational Design & Management
- Product Design
- Computer Systems
- Forensics
- Education
- Ergonomics
- Visual Performance
- Aging

NON-MEMBERS WELCOME

Baltimore, Maryland

For information call or write:
Ann Amrheim
Williams & Wilkins Co.
428 E. Preston Street
Baltimore, MD 21202
(301)528-4259



Merging Pilot and System

...A unique Engineering Challenge.

At over twice the speed of sound, time is critical in obtaining valuable flight data. Pilots require sophisticated display systems that gives them instant access to navigation, target acquisition, threat identification and flight systems information. Making the aircraft and its complex systems an extension of the pilot's will is the challenge you can meet in one of the following professional openings:

Section Manager

Directing a department of 30 engineers and support personnel, you will be responsible for the design of CRT based display systems from concept through production. Display design will include LVPS, HVPS, CRTs, Video and Deflection amps. Your functions will also encompass proposal and budget preparation.

Requires a minimum of 10 years' display design experience including 2 years at the management level. Excellent communication skills are necessary. A background in military products is helpful.

Display Design Engineer

Responsible for design of CRT display system involving analog and digital circuit design and analysis; specification of CRTs and HVPS; analog and digital video processing; A/D and D/A conversion at rates up to 100Mhz; electronic optics correction, deflection and dynamic focus amps.

Requires BSEE or equivalent with 6 plus years' experience in CRT display circuit design, including elementary thermal analysis, grounding and EMI techniques.

Low Voltage Power Supply Engineer

Responsible for design of LVPS that are off-line, pulse width modulated multiple output voltage, 100-500 watts at 85% efficiency operating at frequencies up to 100 Kilohertz. Involves circuit design and analysis, magnetics design and specification, EMI and packaging.

Requires 6 plus years' experience designing LVPS for custom packaging in CRT display systems and BSEE or equivalent. Familiarity with military LVPS, airborne LVPS, system grounding, detailed magnetics design and computer-aided circuit analysis is desired.

Send your resume for prompt consideration to: **Professional Employment, Dept. SJM163, 2701 Orchard Park Way, San Jose, CA 95134.** An Equal Opportunity/Affirmative Action Employer.

KAISER ELECTRONICS



Advertisers Index

Ad-Vance Magnetics, Inc.	25
Burton Browne Advertising	
Artistic Glass Products Co.	29
Balzars Optical Group	15
Royal Associates	
Bourbon Street Associates	11
CELCO (Constantine Engineering Labs. Co.)	19, Cover IV
Stano Advertising	
Citronix Inc.	8
Eagle Magnetic Co.	1
Owen & Owen, Inc.	
EG&G Gamma Scientific	Cover III
Bowen & Associates	
Human Factors Society	34
Kaiser Electronics	35
Thompson Recruitment Advertising	
Litton Electronic Devices	13
Bonfield Associates	
Magnetic Radiation Laboratories Inc.	14
Harrison Advertising	
Microvision	14
Morgan Grampian Exposition Group	24
Nimmo Enterprises	29
Photonics Technology Inc.	30
Photo Research	22
Darryl Lloyd Inc.	
Polytronix, Inc.	11
Quantum Data	Cover II
M.G. Walther Advertising	
Southwest Vacuum Devices Inc.	2
Owens & Associates	
Special Purpose Technology Corp.	6
Sperry Aerospace & Marine Group	31
21 North Advertising	
Teledyne Micronetics	7
Westinghouse Electric Corp.	4
Ketchum Advertising	

BUSINESS STAFF

Eugenie L. Gray
Publishing Director

Leslie A. Saunders
Marketing Manager

Richard Johnston
Production Assistant

Business Office: 212/687-3836

REGIONAL SALES OFFICES

New England

The Boston Man
PO Box 207
Hingham, MA 02043
617/848-9306
N. Wood

New York, New Jersey

C. Lynn Coy & Associates
55 Forest Street
Stamford, CT 06902
203/327-4626
Ted Taylor

Mid Atlantic

C. Lynn Coy & Associates
336 King of Prussia Road
Radnor, PA 19087
215/687-9811
Nancy Hunter

Southeast

C. Lynn Coy & Associates
55 Forest Street
Stamford, CT 06902
203/327-4626
Al Junge

Midwest

C. Lynn Coy & Associates
3412 Main Street
Skokie, IL 60076
312/673-8899
Al Riefenberg

West Coast

Ted Lucas
P.O. Box 852
Cedar Glen, CA 92321
714/337-8889

RECRUITMENT ADVERTISING

MetaData Inc.
310 East 44th Street
New York, NY 10017
212/687-3836
Leslie A. Saunders

Joseph A. MacDonald
Editorial Director

Automatic Measurement of CRT's



The GS-1000 System presents a revolutionary technique of automatically measuring the visual characteristics of cathode ray tubes.

During measurement nothing moves but the beam.

The system uses a computer to move the beam.

Spot size, centroid location (deflection linearity), and luminance are developed in digital form in one set of measurements.

Measurements may be made at any specified set of locations within the display field, typically up to 49.

The system is fast: 10 seconds per location; and accurate: up to one ten thousandth of the display width. No measurement labor or skill required.

Operator errors disappear.

Color measurements may be included.

Call or write today.

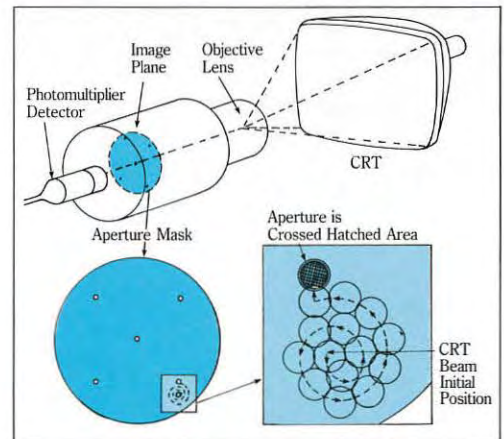

*Where "Optical Radiation is Our Business,
and Performance—Our Reputation"*

EG&G GAMMA SCIENTIFIC

3777 Ruffin Road, San Diego, CA 92123

Tel: (619) 279-8034 Cable: GAMSISD, Telex: 69-7938

West Coast call (619) 279-8034 or (818) 344-3696; East Coast call (617) 745-3200; Central States call (312) 640-8233; Mid Atlantic States call (609) 452-7772; Southeast call (904) 383-0758; Northwest call (408) 735-1450.

Ultra-High Speed and Resolution Color Film Recording Systems



CELCO CFR 8000A Color Film Recording System shown above with DEC-VAX option.

for LANDSAT, Animation and Presentation Business Graphics

SPECIFICATIONS	Celco 8000A	Celco 8000B	Celco 5000A	Celco 5000B
■ Resolution	7500 resolvable pixels		4200 resolvable pixels	
■ CRT Size	7" diameter CRT (0.0008" spot size)		5" diameter CRT (0.0008" spot size)	
■ Recording Speed	Less than 20 seconds for a complex 35mm graphics slide (run length encoded)			
■ Variable Pixel Rates	From 400ns/pixel to 6.2μs/pixel, in 400ns increments			
■ Addressability	4096 x 8192 (pixel x pixel), 8192 x 8192 (Run length encoded)			
■ Film Format Flexibility	Multi Format from 16mm to 8" x 10"	Fixed, selectable from 16mm to 8" x 10"	Multi Format from 16mm to 8" x 10"	Fixed, selectable from 16mm to 8" x 10"
■ Graphic Arts Workstations Interface Compatibility	Includes Autographix, Artronics, Executive Presentation Systems, MAGI, Management Graphics			
■ Mainframe Compatibility	DEC-LSI-11, PDP-11 and VAX; Perkin-Elmer 3200 series; IBM channel			
■ Device Independent Graphics Software Compatibility	ISSCO, UNIRAS			



For complete details circle reader service number or call CELCO today.

CONSTANTINE ENGINEERING LABORATORIES COMPANY

70 Constantine Drive Mahwah, NJ 07430
1150 E. Eighth Street Upland, CA 91786

TEL: 201-327-1123
TEL: 714-985-9868